



ART 258

SIGE S.P.A.

60020 POLVERIGI (AN) ITALY

TEL +39 071 90 90 000 R.A. - FAX +39 071 90 90 804

WWW.SIGE-SPA.IT INFO@SIGE-SPA.IT

REV 00.2021

FOIST00004

PRODOTTO ED ASSEMBLATO IN ITALIA / MADE AND ASSEMBLED IN ITALY / FABRIQUÉ ET ASSEMBLÉ EN ITALIE / HECHO Y MONTADO EN ITALIA

CARATTERISTICHE • FEATURES • CARACTÉRISTIQUES • CARACTERÍSTICAS

Meccanismo per colonna estraibile con Kit guide ad estrazione totale con soft, portata 50 kg, completo di staffe fissaggio antina.

Mechanism for pull-out larder with kit of full extension slides with soft, capacity 50 kg, complete with brackets for fixing door.

Mécanisme pour une colonne extractible avec kit de glissières à extraction totale avec amortisseur, capacité de charge 50 Kg, complet de ferrures de fixation.

Mecanismo para columna extraíble con set de guías de extracción total con amortiguador, carga 50kg, completo de escud para ajustar la puerta.

MINUTERIA INTERNA • FITTINGS • FERRURE • FERRETERIA

N° 24 3,5x18 Viti autofilettante / Self-tapping screws / Vis auto-taraudeuses / Tornillos autorroscantes

N°1 M6x16 Vite / Screw / Vis / Tornillo

N°1 M6x25 Vite / Screw / Vis / Tornillo

N°3 M5x15 Vite / Screw / Vis / Tornillos

N°6 6.2x13.5 Eurovite / Eurovite / Eurovite / Eurovite

N°1 Ø3 Chiave esagonale / Key exagonal / Clés exagonal / Llave hexagonal

COMPONENTI • PARTS • COMPOSANTS • COMPONENTES

A. N°1 Telaio inferiore / Bottom frame / Chassis inférieur / Bastidor inferior

B. N°1 Telaio superiore / Top frame / Chassis supérieur / Bastidor superior

C. N°1 Guida inferiore / Bottom slide / Glissière inférieure / Guía inferior

D. N°1 Guida superiore / Top Slide / Glissière supérieure / Guía superior

E. N°3 Staffa attacco antina / Door bracket / Équerre de façade / Escuadra para ajuste puerta

F. N°2 Inserto speciale di serraggio / Fixing support / Support spécial de fixation / Soporte de fijación

G. N°1 Cover / Cover / Couverture / Cobertura

H. Kit cesto ed attacco cesto green line / Green line basket and basket support kit / Kit panier et clips de fixation panier Green Line / Kit cesto y fijación para cesto Green Line

I. Kit cesto ed attacco cesto Infinity line / Infinity line basket and basket support kit / Kit panier et clips de fixation panier Infinity Line / Kit cesto y fijación para cesto Infinity Line

J. Kit cesto ed attacco cesto Infinity Plus / Infinity Plus basket and basket support kit / Kit panier et clips de fixation panier Infinity Plus / Kit cesto y fijación para cesto Infinity Plus

K. Kit cesto ed attacco cesto Materia / Materia basket and basket support kit / Kit panier et clips de fixation panier Materia / Kit cesto y fijación para cesto Materia

UTENSILERIA • TOOLS • OUTILS • INSTRUMENTOS



MANUTENZIONE/ MAINTENANCE/ ENTRETIEN/ MANTENIMIENTO

Pulire con un panno morbido ed asciutto. Evitare l'uso di solventi e/o abrasivi.

Clean with a soft, dry cloth. Avoid using solvents or abrasive.

Nettoyez avec un chiffon sec et doux. N'utilisez pas aucun solvant ou produit abrasif.

Limpiar con paño suave y seco. Evitar el uso de solventes y/o abrasivos.

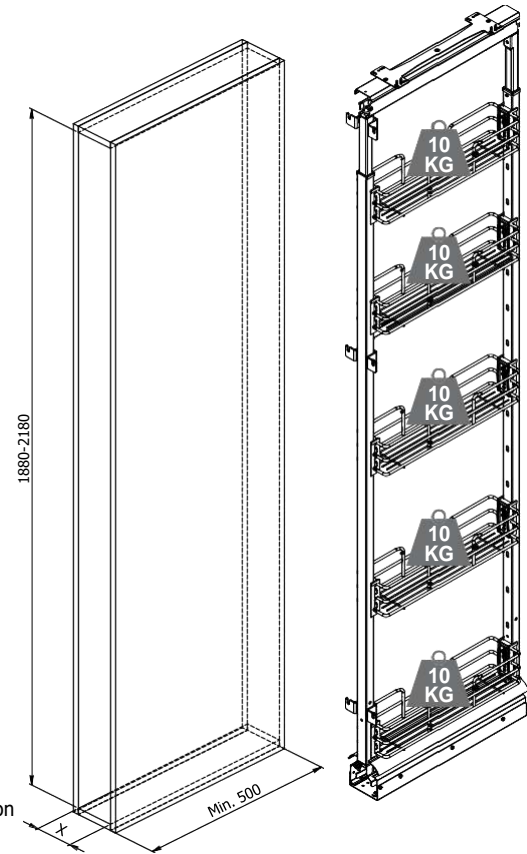

	X Min
150	110
200	160

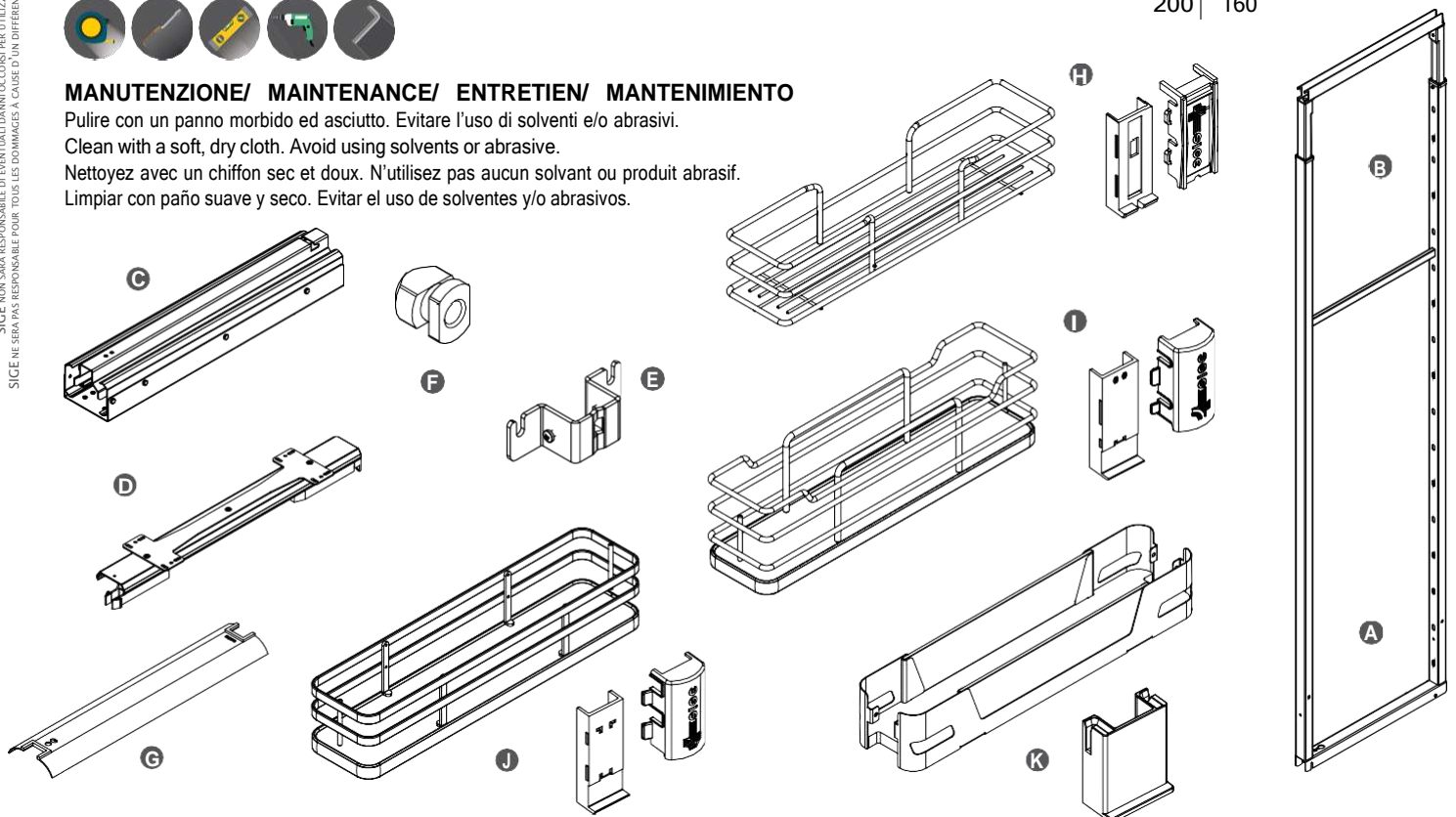

N°20 3.5x18



1

Installare la guida inferiore C e la guida superiore D, con le apposite viti 3.5x18, come mostrato.

Install the bottom slide C and the top slide D, with the 3.5x18 screws, as shown.

Installez la glissière inférieure C et la glissière supérieure D, avec les vis 3,5x18, comme illustré.

Instale la corredera inferior C y la corredera superior D con los tornillos 3.5x18, como se muestra.

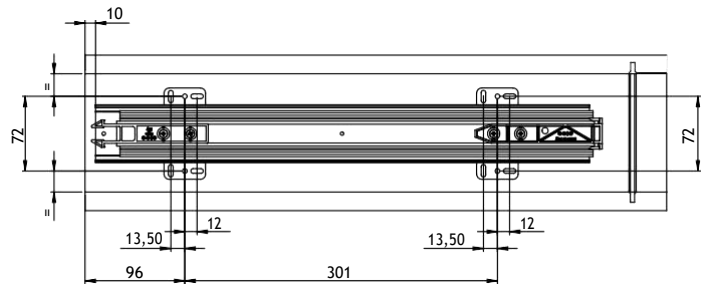
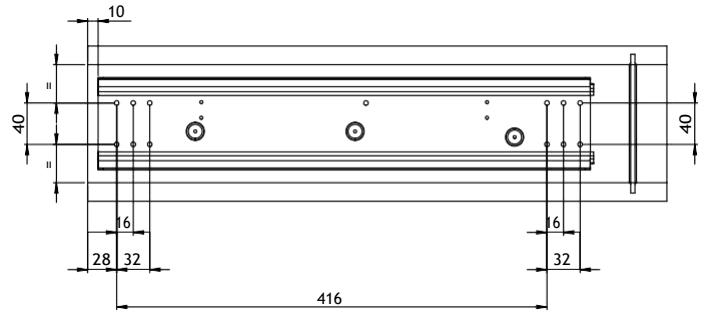
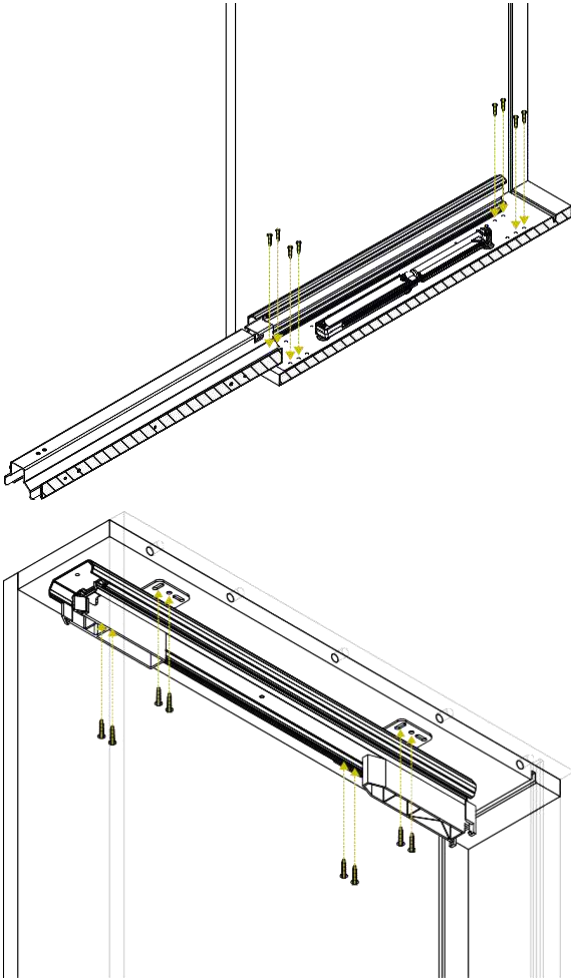

N°1 M6x16 N°1 M6x24



2

Premontare le viti M6x16 e M6x24 come mostrato.

Pre-assemble the M6x16 and the M6x24 screws as shown.

Pré-assembler les vis M6x16 et M6x24 comme indiqué.

Premonte los tornillos M6x16 y M6x24 como se muestra.

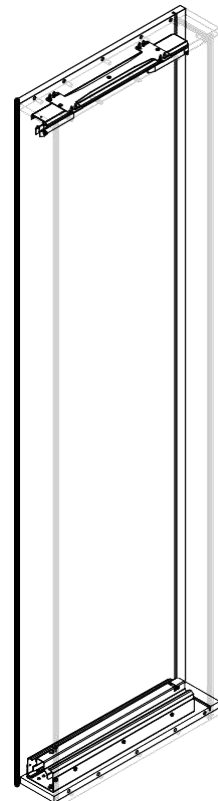
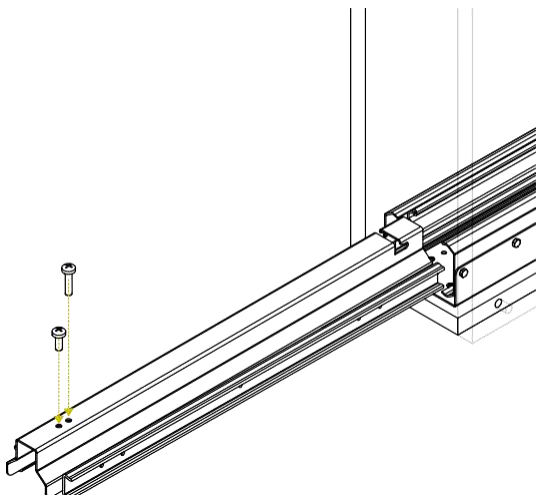

3

Installare il telaio A,B sulla guida inferiore C, fissare il telaio A,B sulla guida inferiore C serrando la vite M6x24, come mostrato.

Install the A,B frame in to the bottom slide C, fix the A,B frame on the bottom slide C by tightening the M6x24 screw, as shown.

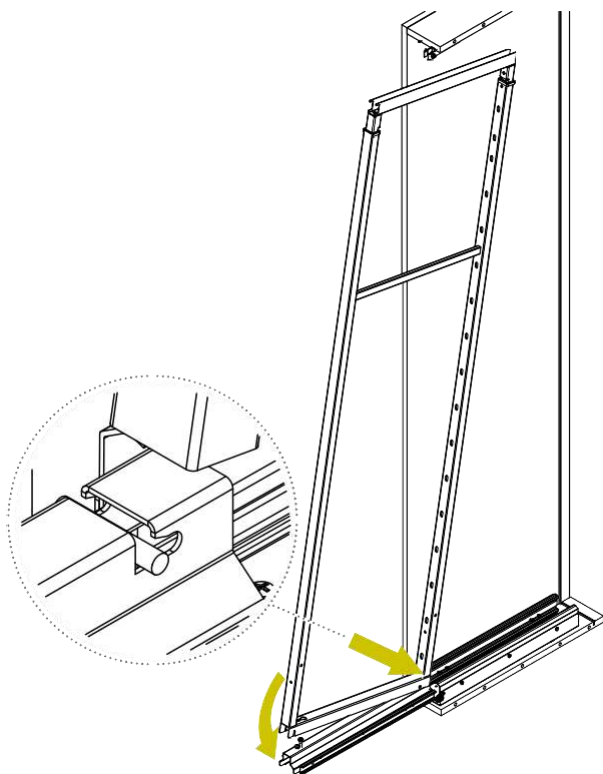

Installez le châssis A, B dans la glissière inférieure C, fixez le châssis A, B sur la glissière inférieure C en serrant la vis M6x24, comme illustré.

Instale el bastidor A, B en la guía inferior C, fije el bastidor A, B en la guía inferior C apretando el tornillo M6x24, como se muestra.

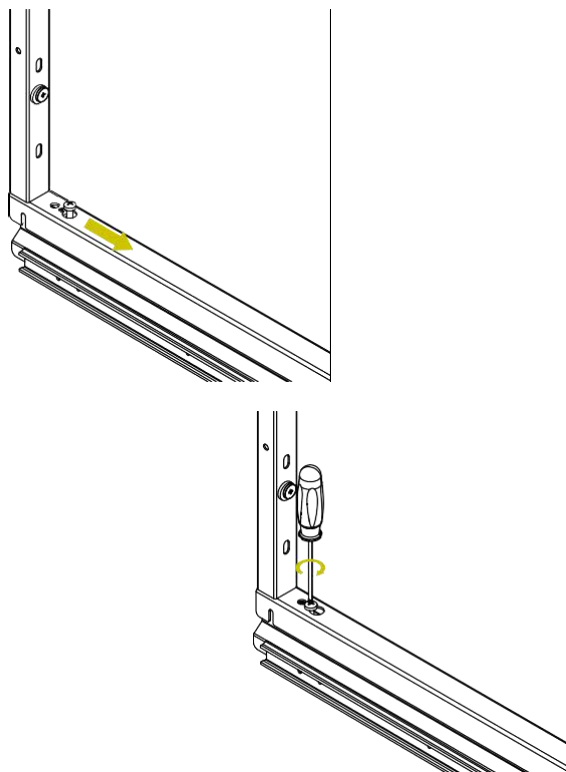
**4**

Allentare i due grani "n" (sul telaio A) e far scorrere il telaio B.
Bloccare il telaio B alla quota indicata tirando i grani "n".
far scorrere il telaio A,B sulla guida superiore D fino al "click!" per installare.

Loosen the grains "n" (on the frame A) and slide up the frame B.
Block the frame B at the indicated measure by tightening the grains "n".
Slide the frame A,B into the top slide D until "click!" to install.

Desserrez les grains "n" (sur le cadre A) et faites glisser le châssis B.
Bloquez le châssis B à la mesure indiquée en serrant les grains "n".
Faites glisser le cadre A, B dans la glissière supérieure D jusqu'à ce que "click!" à installer.

Afloje los granos "n" (en el marco A) y deslice hacia arriba el bastidor B.
Bloquee el bastidor B en la medida indicada apretando los granos "n".
Deslice el bastidor A, B en la guía superior D hasta "click!" instalar.

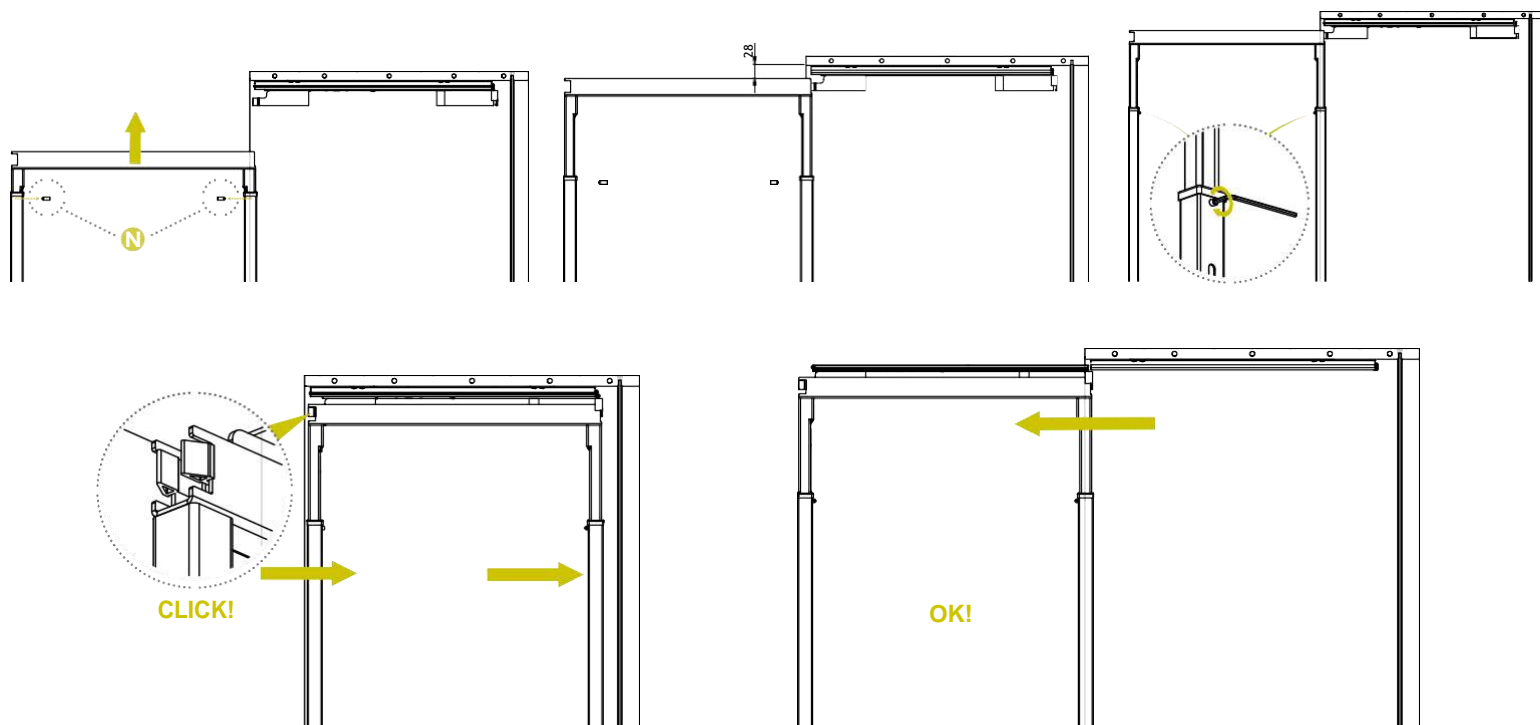

N°6.2x13.5



5

Scegliere l'altezza della staffa attacco antina E intermedia (vedi quota L), quindi preforare l'antina, Ø5x12mm, rispettando le quote indicate. Premontare le euroviti 6.2x13.5.

Choose the position of the middle door bracket E (see measure L), then pre drill, Ø5x12mm, the door according to the measure given. Pre-assemble the 6.2x13.5 eurovite.

Choisissez la position du équerre du milieu de façade E (voir mesure L), puis pré-percer, Ø5x12mm, la porte selon la mesure donnée. Pré-assembler l'eurovite 6.2x13.5.

Elija la posición del soporte del medio de la puerta E (vea la medida L), luego pretaladre, Ø5x12mm, la puerta de acuerdo con la medida dada. Preensamble el Eurovite 6.2x13.5.

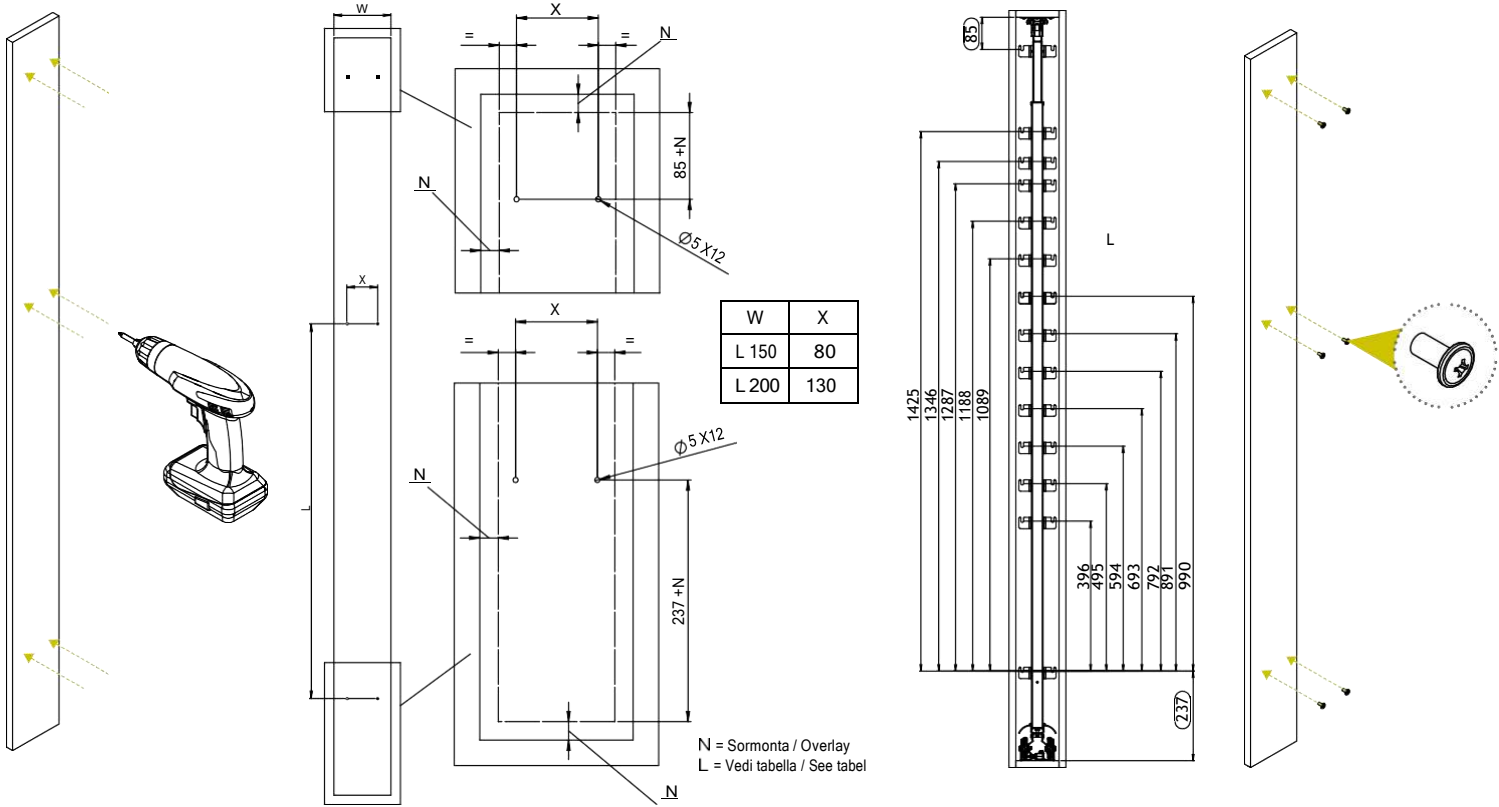

6

Montare l'inserto speciale di serraggio F, come mostrato. Mount the fixing support F, as shown.

Montez le support spécial de fixation F, comme indiqué. Monte el soporte de fijación F, como se muestra.

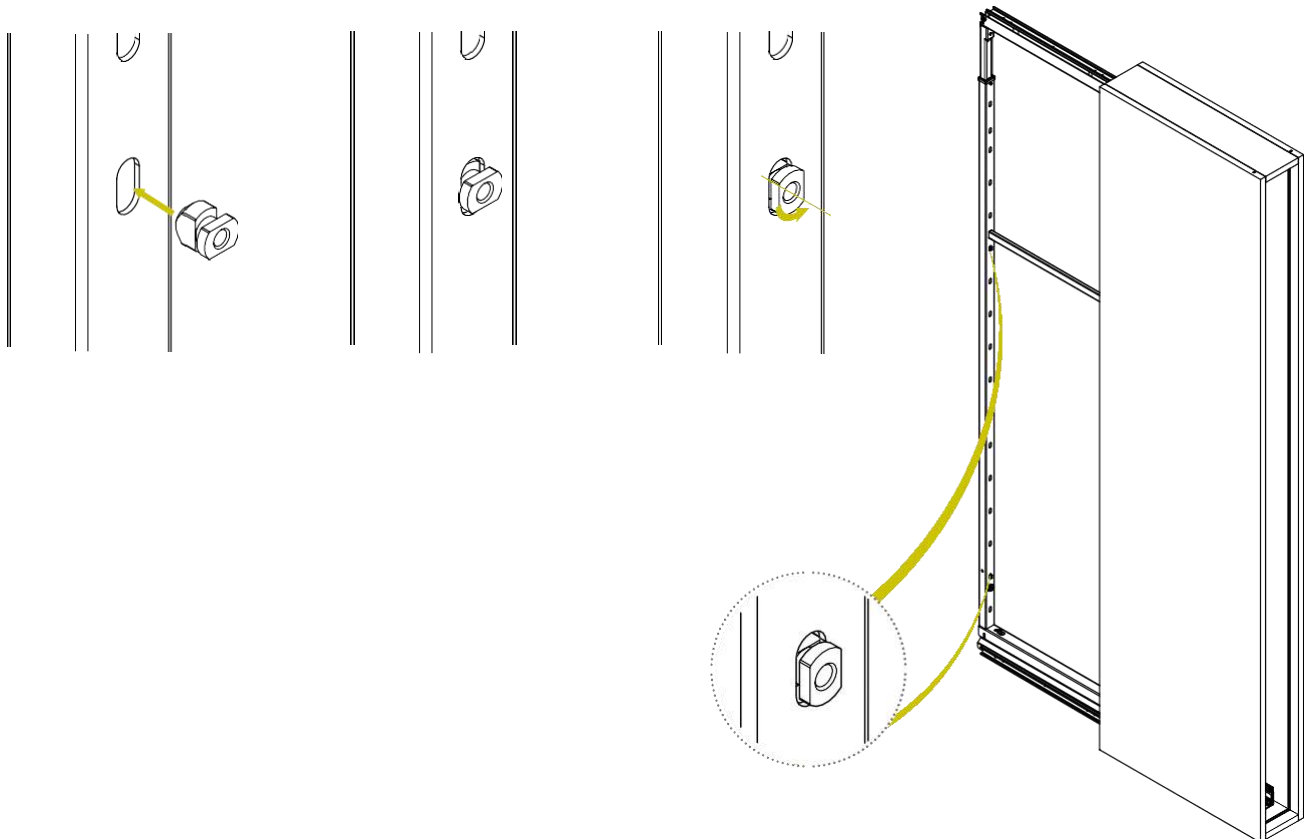

N°3 M5x15



Montare le staffe attacco antina E, fissare con le viti M5x15.
Mount the door bracket E, fix with the M5x15 screws.
Montez les équerre de façade E, fixez avec les vis M5x15.
Monte las escuadras para ajuste puerta E, fije con los tornillos M5x15.

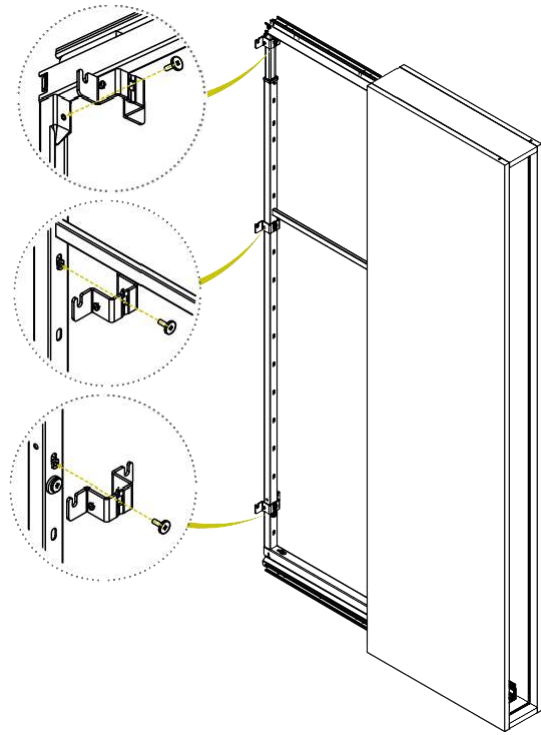

7

8

Montare l'antina sulle staffe attacco antina E, quindi serrare le sei euroviti 6.2x3.5
Mount the door on the door brackets E, then tighten the six 6.2x3.5 eurovite.

Montez la porte sur les équerre de façade E, puis serrez les six 6.2x3.5 eurovite.
Monte la puerta en las escuadras para ajuste puerta E, luego apriete los seis 6.2x3.5 eurovite.

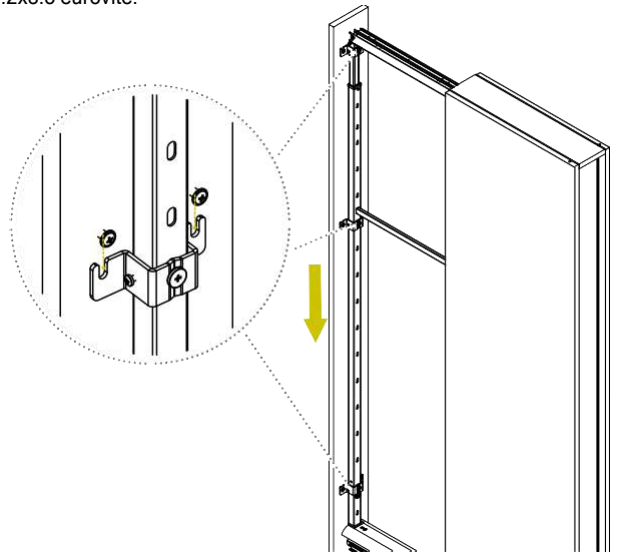
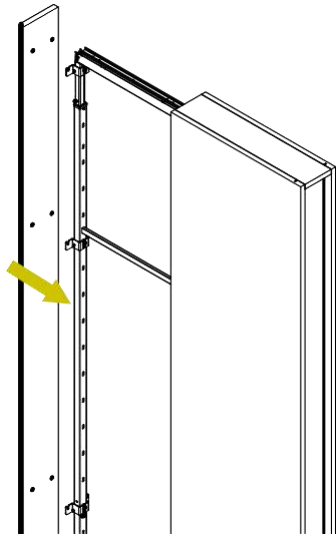

9

Agire sulle viti laterali della staffa attacco antina E per regolare l'antina a destra ed a sinistra.

Travaillez sur les vis latérales du les équerre de façade E pour régler la porte à droite et à gauche.

Work on the side screws of the door bracket E to adjust the door right and left.

Trabaje con los tornillos laterales del las escuadras E para ajustar la puerta a derecha e izquierda.

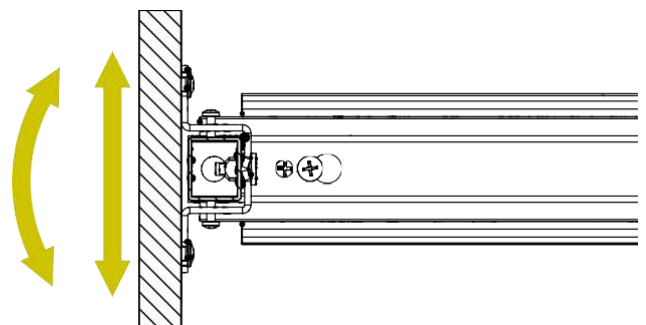
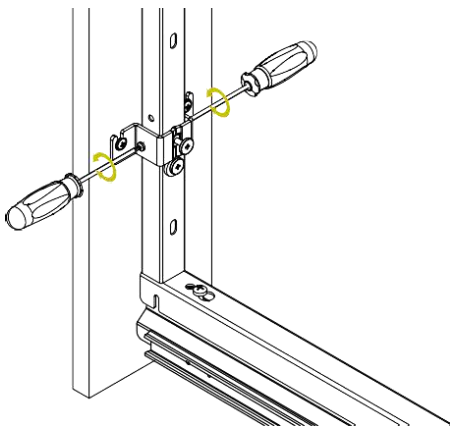

10

Agire sulla vite eccentrica presente sul telaio inferiore A per regolare l'antina su e giù.

Work on the eccentric screw on the bottom frame A to adjust the door up and down.

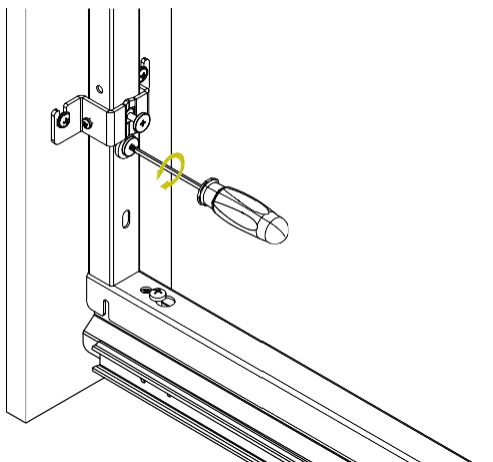

Travaillez sur les vis excentriques sur le châssis inférieur A pour régler la porte de haut en bas.

Trabaje con los tornillos excéntricos en el bastidor inferior A para ajustar la puerta hacia arriba y hacia abajo.

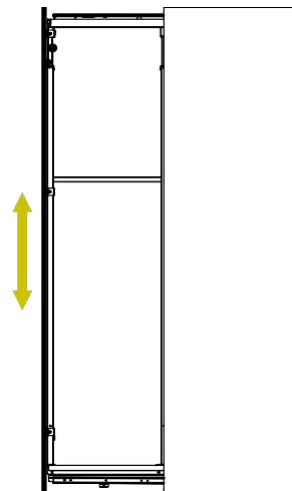
**11**

Agire sulle viti M6x16 e M6x24 presenti sulla guida inferiore C per regolare l'angolo dell'antina.

Work on the M6x16 e M6x24 screw on the bottom Slide C to adjust the angle of the door.

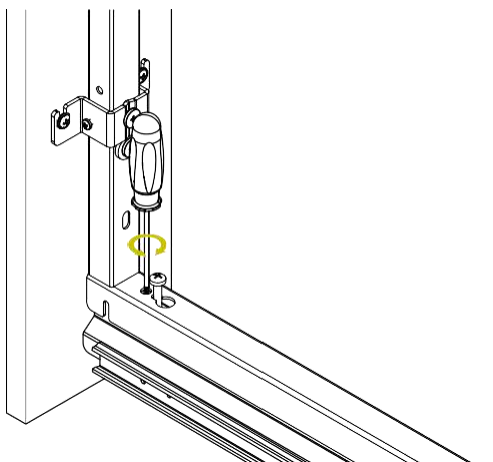

Travaillez sur la vis M6x16 et M6x24 sur le glissière inférieure C pour ajuster l'angle de la porte.

Trabaje con el tornillo M6x16 e M6x24 en la guía inferior C para ajustar el ángulo de la puerta.

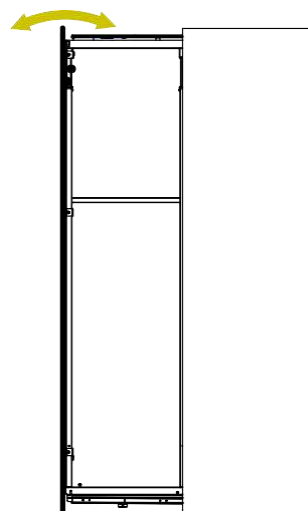
**12**

Inserire il cover G come mostrato.

Put the cover G as shown.

Placez le couverture G comme indiqué.

Coloque la cobertura G como se muestra.

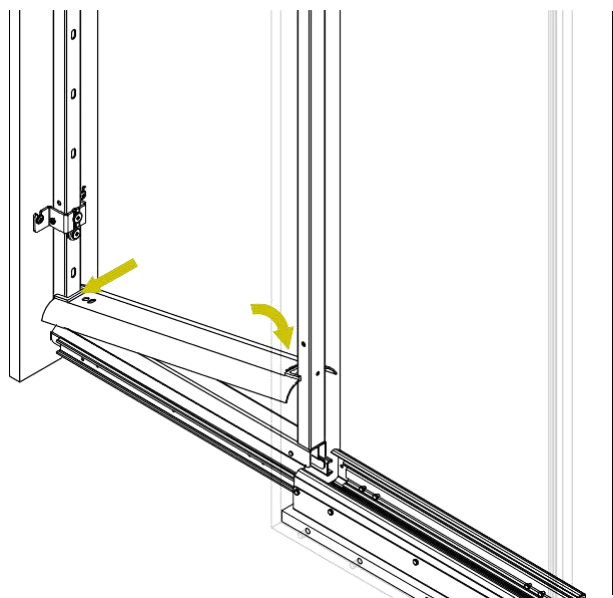

Montaggio cesti.
Basket mounting.
Montage du panier.
Montaje de cesta.

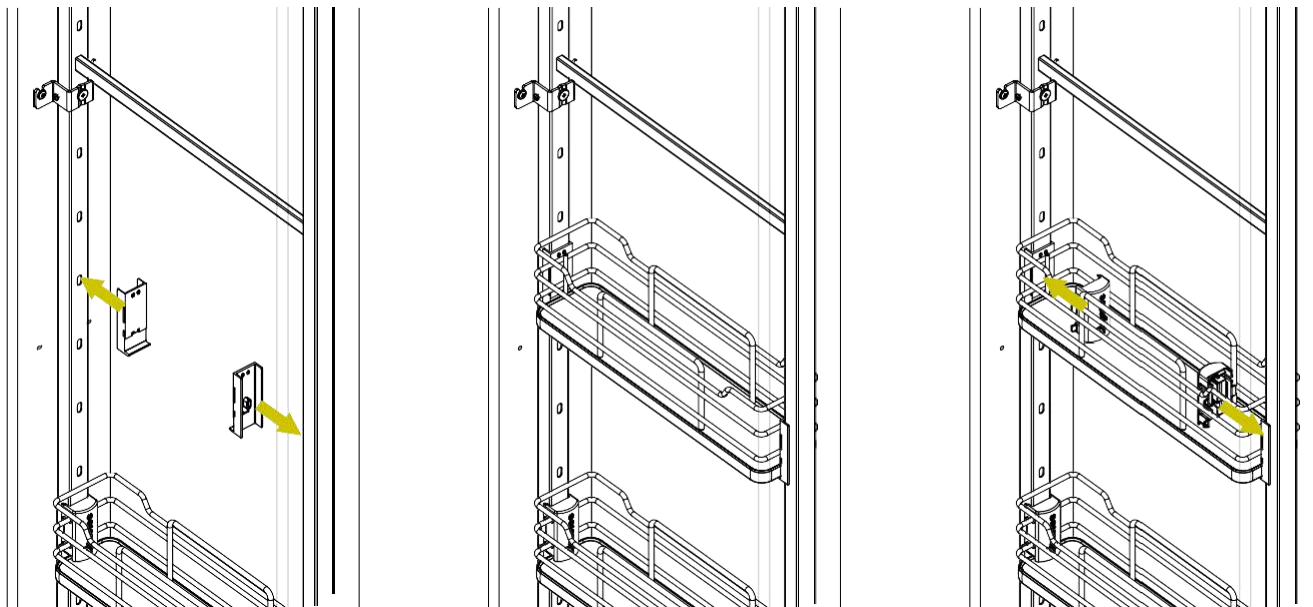

Smontaggio cesti.
Basket removing.
Enlever le panier.
Retirar la cesta.

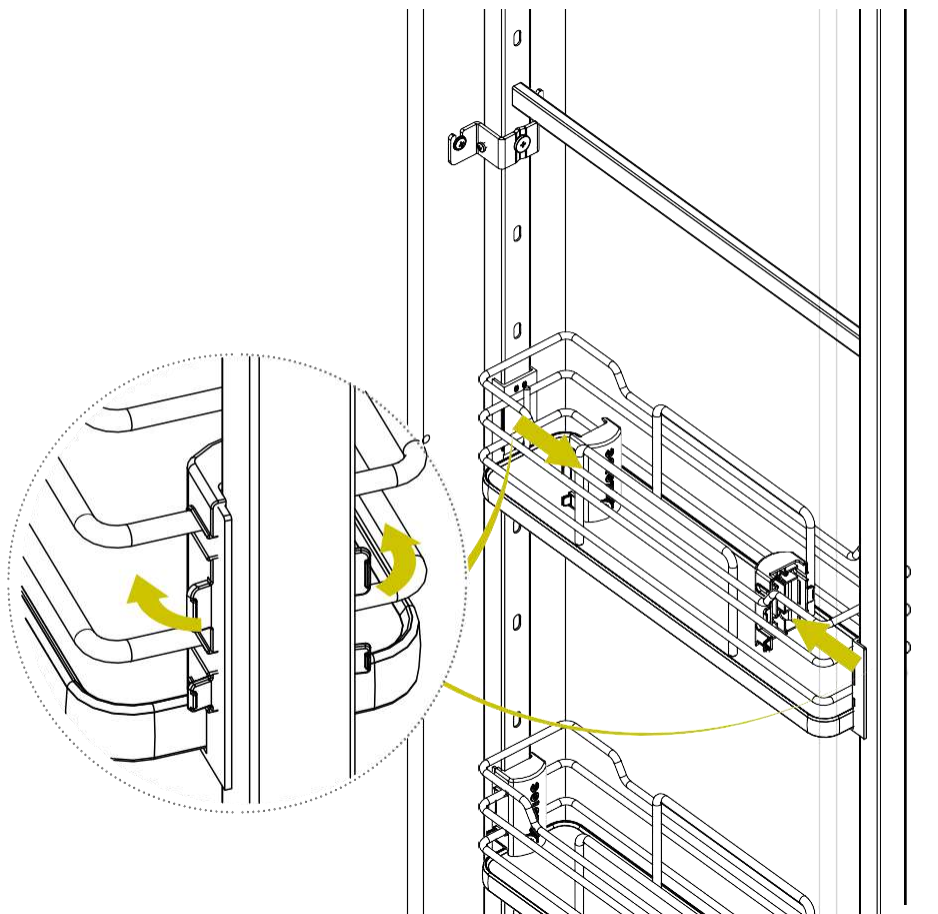

Montaggio cesti Materia.
 Materia basket mounting.
 Montage du panier Materia.
 Montaje de cesta Materia.

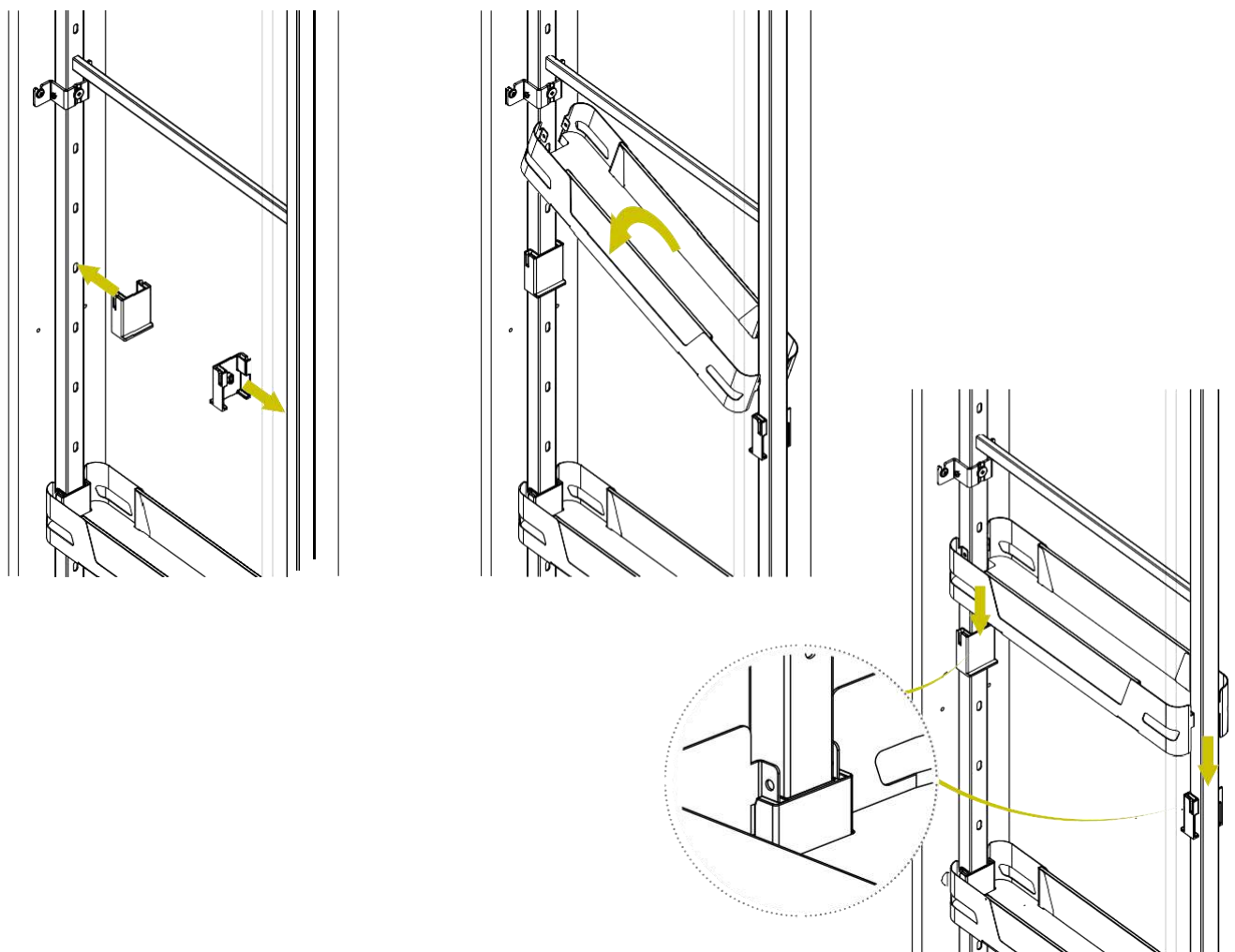

Smontaggio cesti Materia.
 Materia basket removing.
 Enlever le panier Materia.
 Retirar la cesta Materia.

