

ART 350

MONTAGGIO VERSIONE DX . ASSEMBLY RIGHT VERSION
MONTAGE VERSION DROITE . MONTAJE VERSION DERECHA



SIGE S.P.A.
60020 POLVERIGI (AN) ITALY
TEL +39 071 90 90 000 R.A. - FAX +39 071 90 90 804
WWW.SIGE-SPA.IT INFO@SIGE-SPA.IT

REV 00.2022
FOIST00012

PRODOTTO ED ASSEMBLATO IN ITALIA / MADE AND ASSEMBLED IN ITALY / FABRIQUÉ ET ASSEMBLÉ EN ITALIE / HECHO Y MONTADO EN ITALIA

CARATTERISTICHE • FEATURES • CARACTÉRISTIQUES • CARACTERÍSTICAS

Meccanismo estraibile per angolo base, con 4 cesti, completo di soft. Versione sx o dx.
Pull-out mechanism for corner base unit, with 4 baskets, complete of soft. Left or right side version.
Mécanisme extractible pour angle de base, avec 4 paniers, complet de soft. Version gauche ou droite.
Mecanismo extraíble para esquinero con 4 cestos, y soft. Disponible izquierdo y derecho.

MINUTERIA INTERNA • FITTINGS • FERRURE • FERRETERIA

N° 27 4x16 Viti autoflettante / Self-tapping screws / Vis auto-taradeuses / Tornillos autorroscantes

COMPONENTI • PARTS • COMPOSANTS • COMPONENTES

- A. N°1 Struttura posteriore / Back structure / Structure postérieure / Estructura posterior
- B. N°1 Struttura laterale / Lateral structure / Structure laterale / Estructura lateral
- C. N°1 Struttura anteriore / Front structure / Structure antérieure / Estructura anterior
- D. N°1 Boccola inferiore / Lower bushing / Douille inférieure / Boquilla inferior
- E. N°1 Boccola superiore / Upper bushing / Douille supérieure / Boquilla superior
- F. N°1 Fine corsa / Stop / Fin de course / Terminal
- G. N°1 Soft / Soft / Soft / Soft
- H. N°2 Staffa fissaggio antina / Bracket / Patte fixation pour la porte / Estructura de fijación para puerta
- I. N°1 Snodo / Joint / Rotule / Junta
- L. N°2 Reggi braccetto / Post-connectors / Douille / Sostén para brazo
- M. N°1 Braccetto / Linking arm / Crochet / Brazo
- N. N°2 Cover / Cover / Cover / Cover
- O. N°1 Dima di foratura / Mounting template / Modèle approprié / Molde para agujeros
- P. N°8 Ganci (dentro la scatola dei cesti) / Hooks (inside basket box) / Crochets (à l'intérieur de la boîte du panier) / Ganchos (dentro de la caja del cesto)

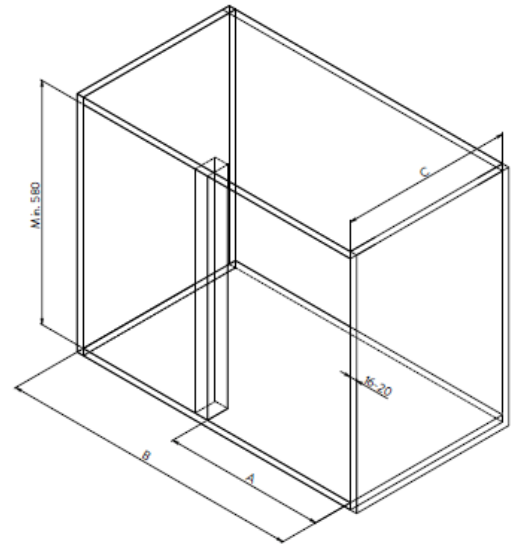

UTENSILERIA • TOOLS • OUTILS • INSTRUMENTOS



MANUTENZIONE • MAINTENANCE • ENTRETIEN • MANTENIMIENTO

Pulire con un panno morbido ed asciutto. Evitare l'uso di solventi e/o abrasivi.
Clean with a soft, dry cloth. Avoid using solvents or abrasive.
Nettoyez avec un chiffon sec et doux. N'utilisez pas aucun solvant ou produit abrasif.
Limpiar con paño suave y seco. Evitar el uso de solventes y/o abrasivos.

DOOR	A	B	C
400	Min. 360	Min. 760	470/505
450	Min. 410	Min. 860	470/505
500	Min. 460	Min. 860	470/505
600	Min. 560	Min. 1050	470/505

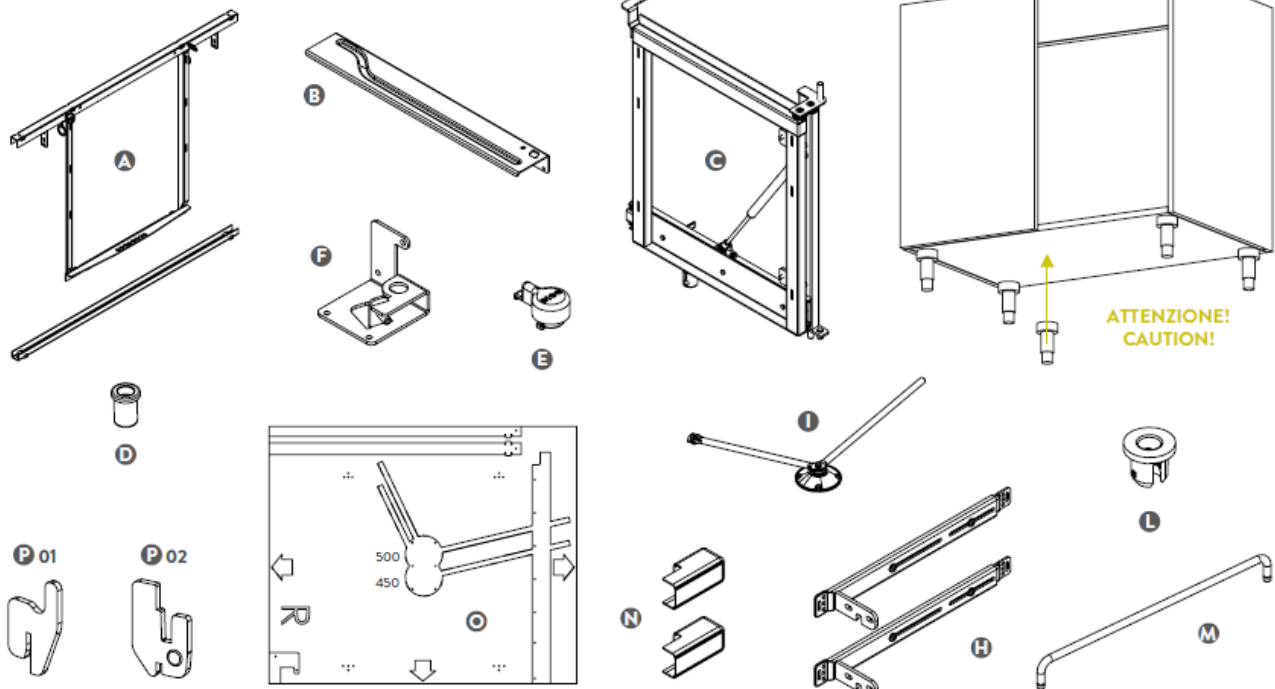

SIGE non è né responsabile né autorizzata per quanto riguarda l'installazione del prodotto. SIGE non è responsabile per danni causati dall'uso improprio del prodotto. SIGE non è responsabile per danni causati dall'uso improprio del prodotto. SIGE non è responsabile per danni causati dall'uso improprio del prodotto.

N°6 4x16

2

Fissare il telaio posteriore A con l'apposita dima e serrare i grani.
Attach the rear frame A with the appropriate mounting template and lock the screw.
Fixez le cadre arrière A utilisant le modèle approprié et bloquer les vis.
Fije el bastidor posterior A con el molde y ajuste los tornillos.

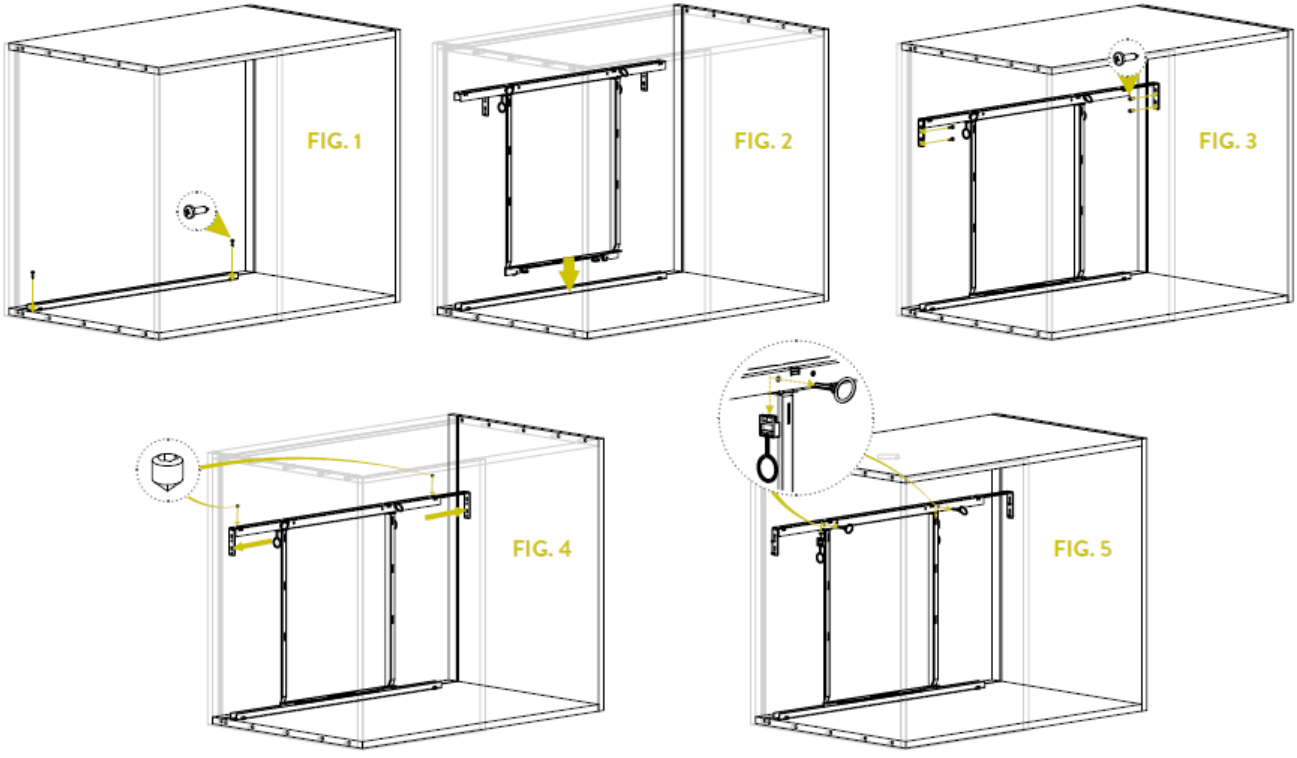

N°9 4x16

3

Posizionare il particolare B e F con l'apposita dima O.
Place the particular B and F with the appropriate mounting template O.
Positionner le particulier B et F utilisant le modèle O approprié.
Posicione los particulares B y F con el molde O.

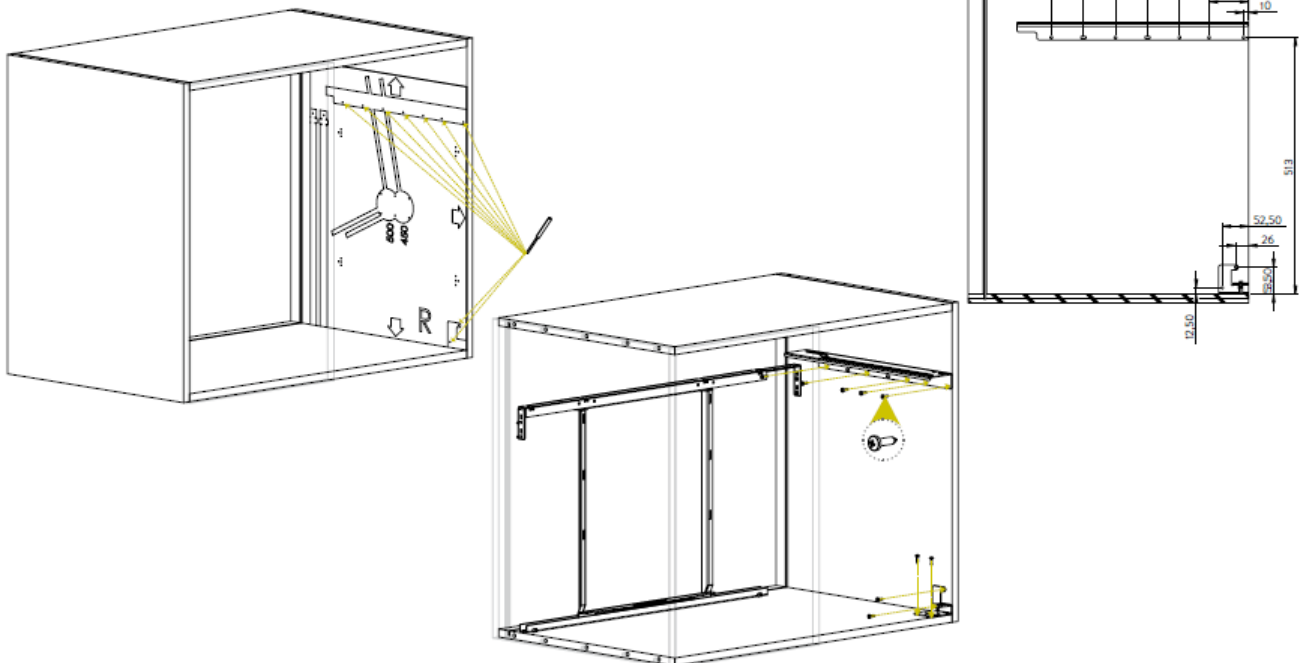

4

Disporre la boccia inferiore D nell'apposito alloggiamento.
 Put the lower bushing D in the hole.
 Préparez la douille inférieure D dans son espace.
 Disponga la boquilla inferior D en su agujero.

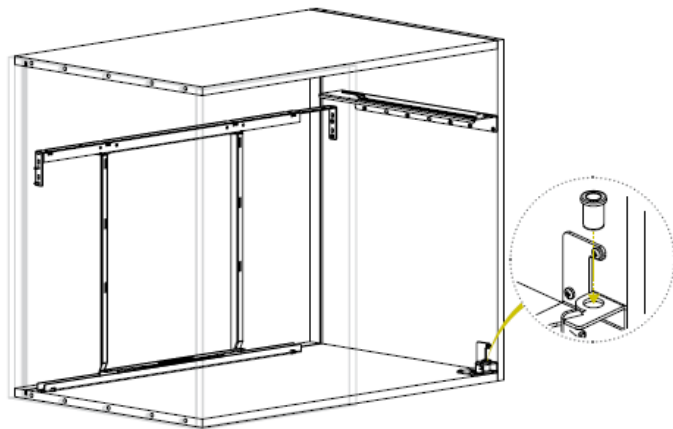
**5**

Montare la struttura anteriore C nella struttura B e fine corsa F e accertarsi che il cuscinetto sia posizionato nell'apposito binario.

Montez la structure antérieur C dans le châssis B e F; contrôlez que le roulement soit dans sa voie.

Put the front structure C in the frame B e F. Check if the bearing is in the track.

Monte la estructura anterior C en la estructura B y el terminal F, asegúrese de que la almohadilla este posicionada en su riel.

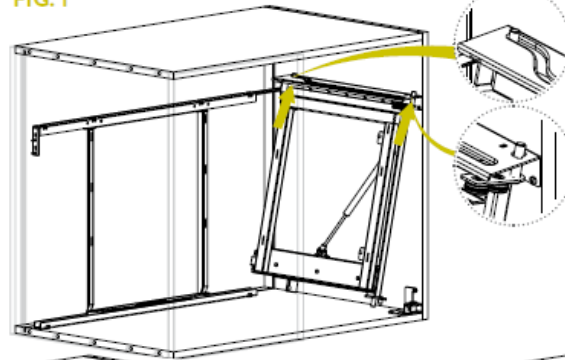
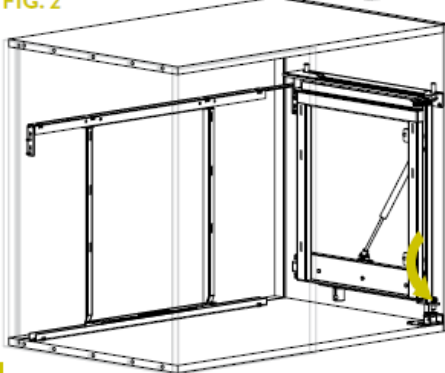
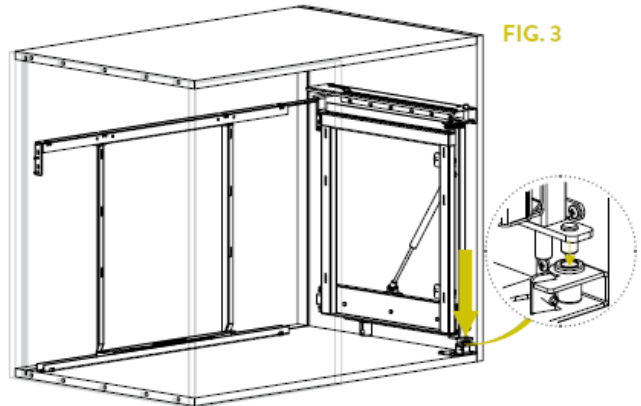
FIG. 1**FIG. 2****FIG. 3****6**

Inserire la boccia superiore E e ruotare in senso orario fino all'aggancio (click).
 Fit the upper bushing E and turn clockwise until the hooking (click).

Inserez la douille supérieure E et tournez la dans le sens des aiguilles d'une montre jusque l'accrochage (click).

Inserte la boquilla superior E y gire en sentido horario hasta que se enganche (click).

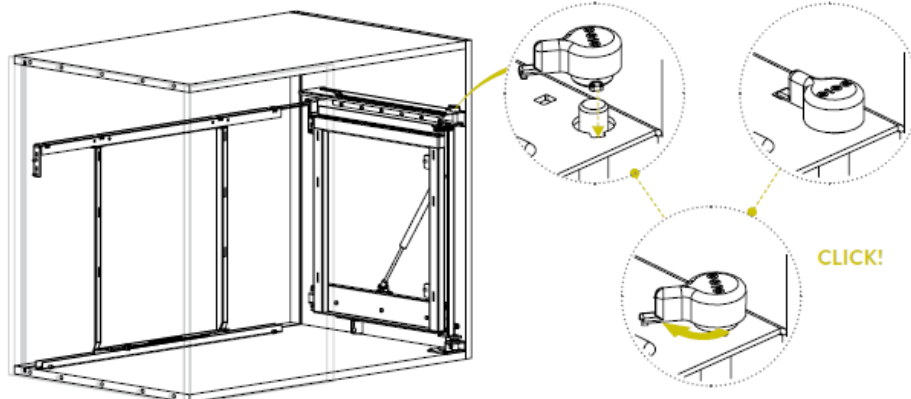

7

Avvitare rispettando l'apposita dima.
Screw according to the mounting template.

Visser observant le modèle spécial.
Atornille respetando el molde.

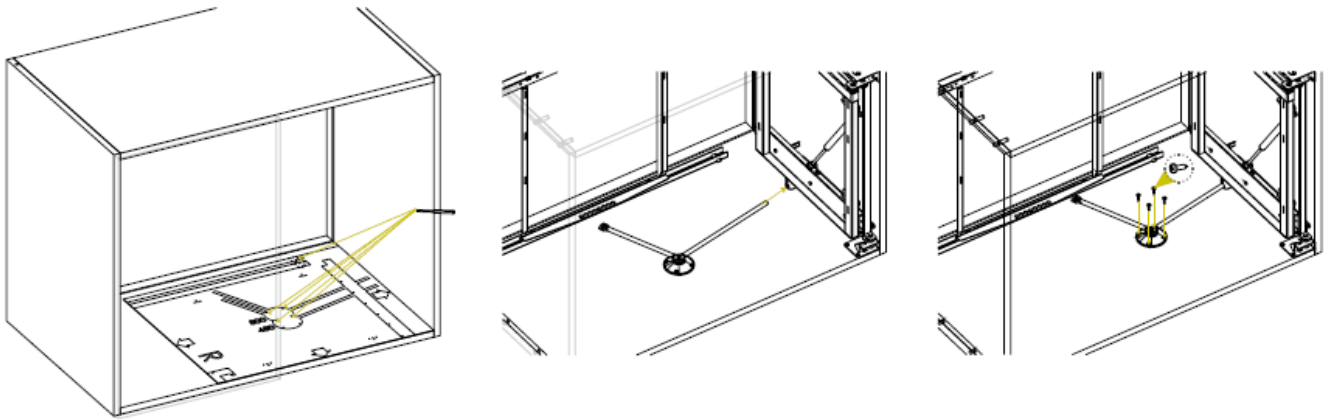

8

Assemblare i reggi-braccetti L e il braccetto M nelle posizioni corrette.
Put together the post-connectors L and the linking arm M.

Assemblez les douilles L et le crochet M.
Monte los sóstenes del brazo L y el brazo M en su posición.

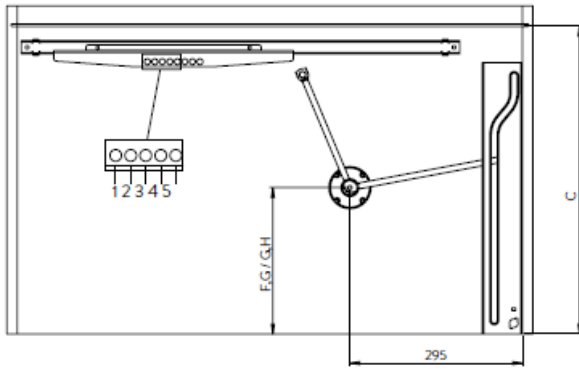

C	DEPTH	FORI/HOLES TROUS/AGUJEROS
470	F,G	2/3
505	G,H	4/5

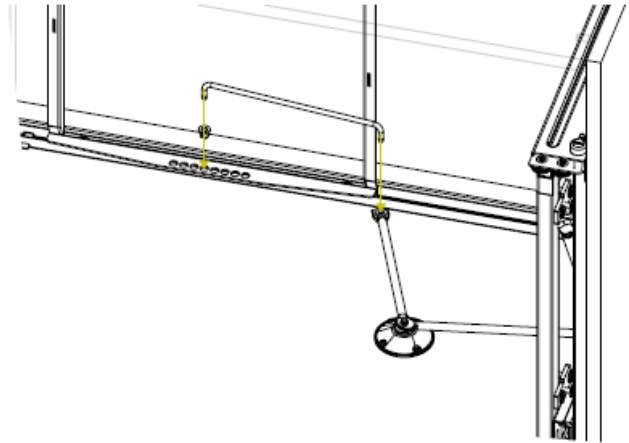

N°8 4x16

9

Montare le staffe di fissaggio H sull'anta rispettando le quote e l'apposita dima, poi collocare sulla struttura anteriore aperta.

Montez les pattes de fixation H pour la porte sur la porte et modèle spécial, selon les mesures de la porte, et placez sur la structure antérieur ouverte.

Fix the front-brackets H on according to the door measures or mounting template and put it on the pulled out front structure.

Montar los estribos de fijación H a la puerta respetando las medidas y el molde, luego colóquelo en la estructura anterior.

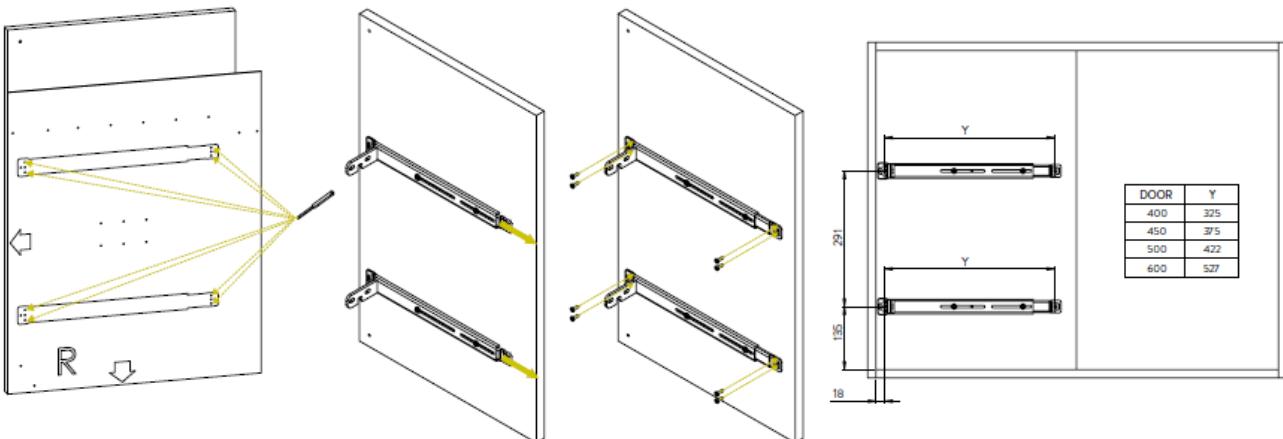

DOOR	Y
400	325
450	375
500	422
600	527

10

Montare l'antina sulle staffe attacco antina E, quindi serrare le sei euroviti 6.2x3.5
Mount the door on the door brackets E, then tighten the six 6.2x3.5 eurovite.

Montez la porte sur les équerre de façade E, puis serrez les six 6.2x3.5 eurovite.
Monte la puerta en las escuadras para ajuste puerta E, luego apriete los seis 6.2x3.5 eurovite.

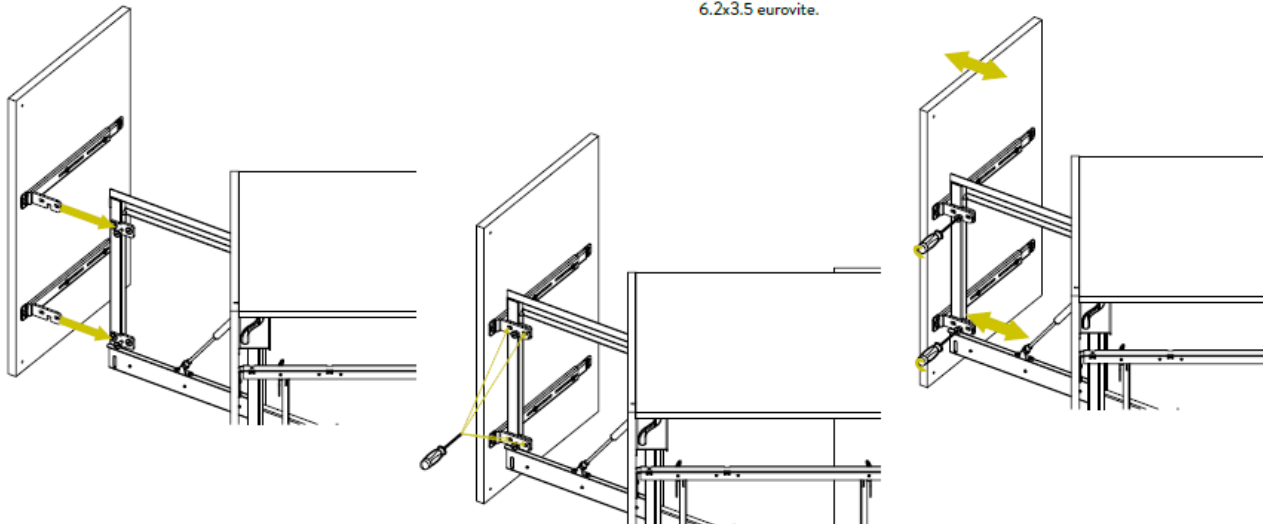

11

Effettuare le regolazioni.
Make adjustments.
Effectuez les réglages.
Efectuar las regulaciones.

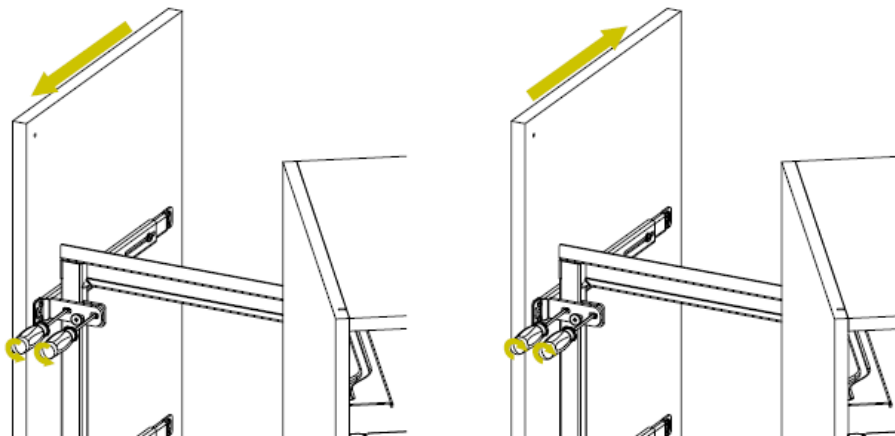

12

Effettuare le regolazioni.
Make adjustments.
Effectuez les réglages.
Efectuar las regulaciones.

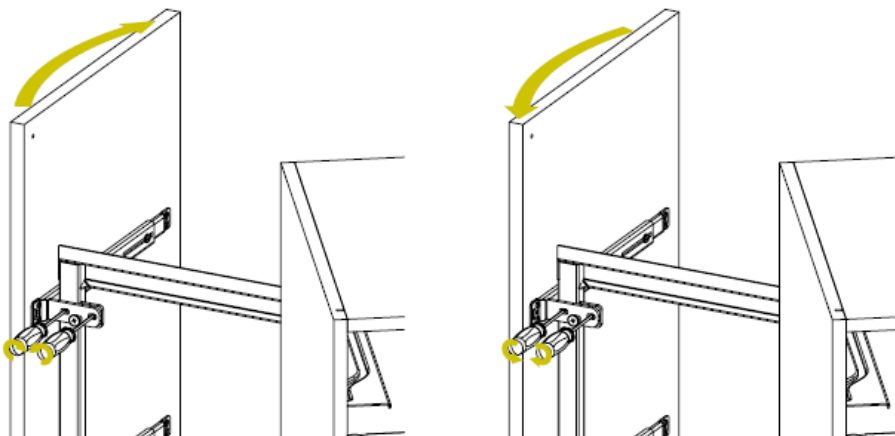



13

Eseguire la regolazione di apertura di fine corsa tramite vite.
Perform the adjustment of opening limit using screw.
Effectuez le réglage de l'ouverture de fin de course utilisant le vis.
Efectuar las regulaciones de abertura limite usando los tornillos.

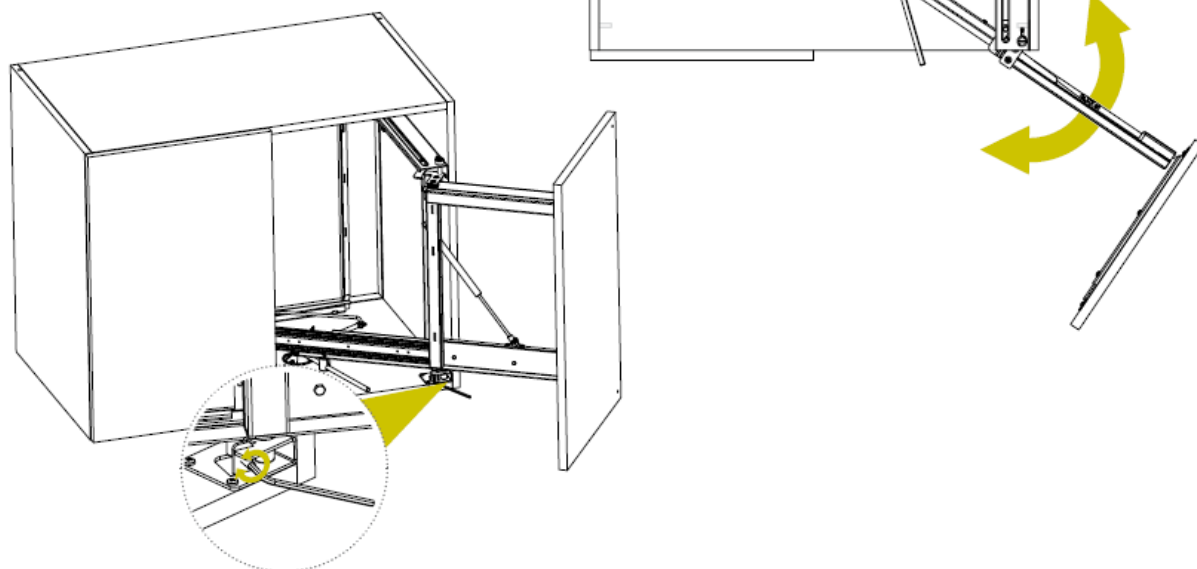

14

Infilare il cover N.
Put the cover N.
Mettre la couverture N.
Insertar la cover N.

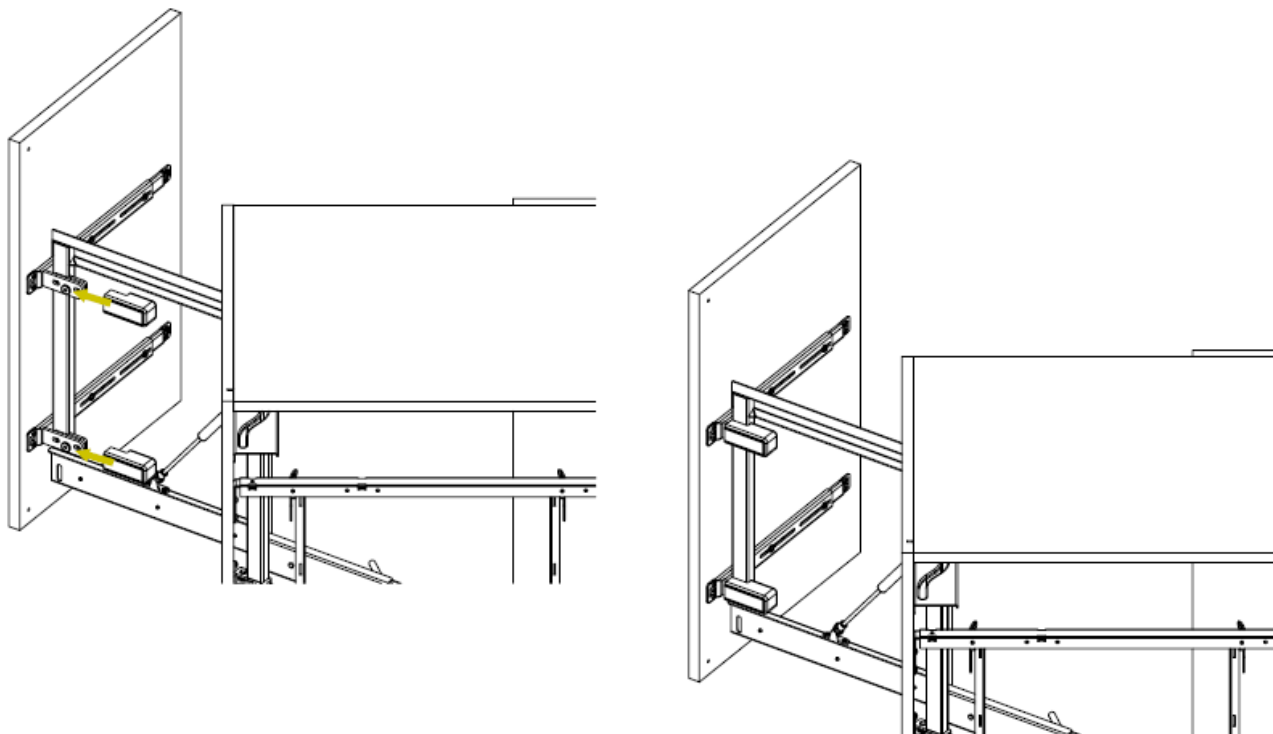

15

Inserire gli appositi ganci per il montaggio dei cesti.
Insert the hooks for mounting baskets.
Insérez les crochets de montage pour les paniers.
Insertar los ganchos para el montaje de los cestos.

350/350i

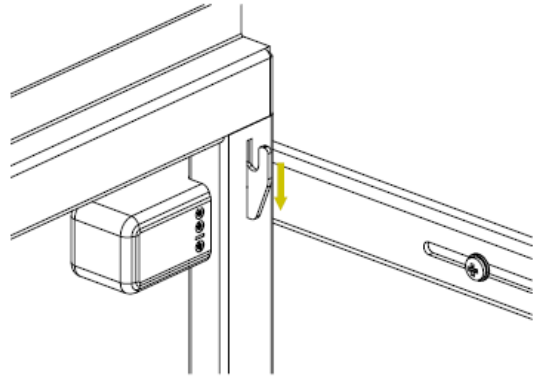
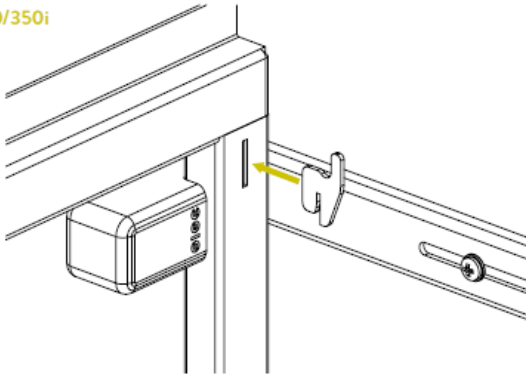

350+

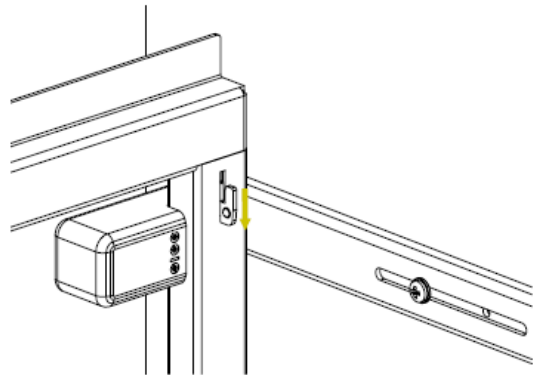
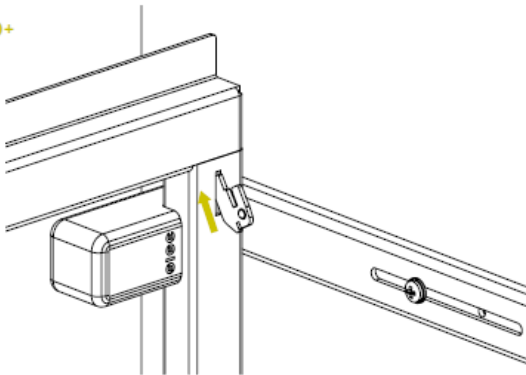

350M
350ME
350PRO

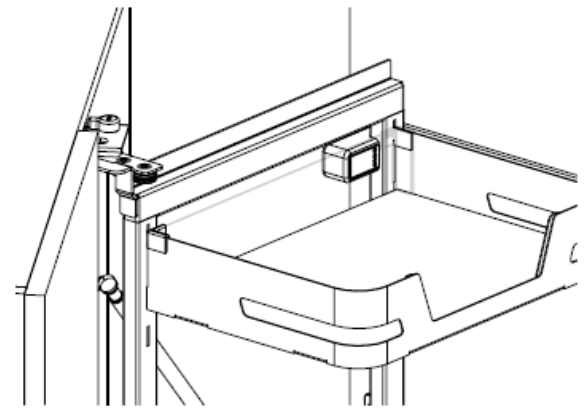
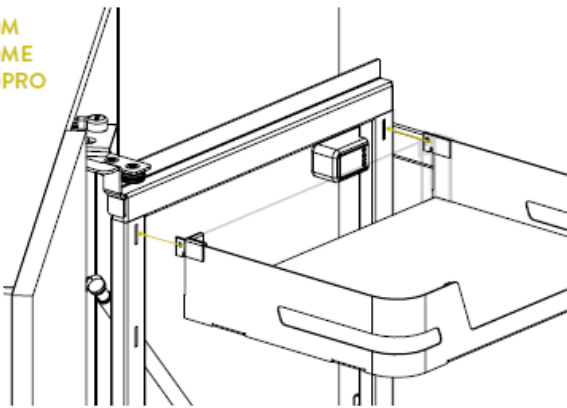

OPTIONAL

350ME

