









Assembly manual for PTJ006

1. Accessories of product

A. (1pcs)	B. (1pcs)	C. (2pcs)	D. (1pcs)	E. (2pcs)	F. (2pcs)	G. (6pcs)	H. (6pcs)
							
		I. (6pcs)					
							

2. According the product shape (φ707×550~850) to choose the suitable cabinet size

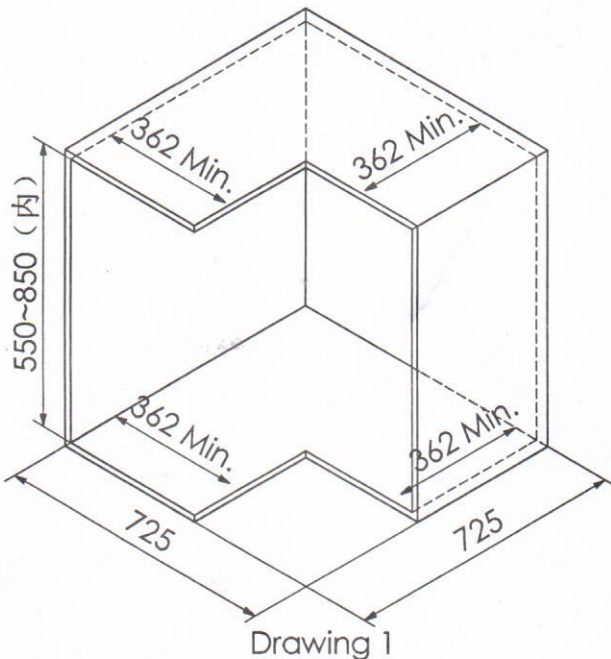

3. Fixing step

1. According the picture size to confirm the location of the straight tube then draw the central line in the bottom board and top board As Drawing 1.
2. According the sequence to fix the A, E, C, E, C, B, As Drawing 2.
3. Use ST4x16 (I) 3pcs fix the straight tube (A) on the bottom board. In the same way use ST4x16 (I) 3pcs fix the adjustable tube (B) on the top board As drawing 3.
4. Adjust the three layers (C) to the suitable height, according the drawing 4 to fix, prevent the baskets fall down and which show the fixing is finished.

