



# ART 119M ART 119ME

GUIDE SIGE - SIGE SLIDES - COULISSES SIGE - GUIAS SIGE

REV 00.2018  
FOIST000088

PRODOTTO ED ASSEMBLATO IN ITALIA / MADE AND ASSEMBLED IN ITALY / FABRIQUÉ ET ASSEMBLÉ EN ITALIE / HECHO Y MONTADO EN ITALIA

## CARATTERISTICHE • FEATURES • CARACTÉRISTIQUES • CARACTERÍSTICAS

Cestello cassetto con fondo in nobilitato, guide ad estrazione totale e soft.  
Solid base pan drawer with full extension slides and soft closing.  
Panier de mélamine Fond de tiroir, diapositives extension complète de soft.  
Cajón estante con panel inferior en melamina, toboganes de extensión completa y soft.

## MINUTERIA INTERNA • FITTINGS • FERRURE • FORRETERIA

N°12 4x16 mm Viti autofilettanti / Self-tapping screws / Vis auto-taraudeuses / Tornillo autorroscante  
N°4 6.3x14 mm Eurovite / Euro-screw / Eurovis / Euro tornillo

## COMPONENTI • PARTS • COMPOSANTS • COMPONENTES

- A. N°1 Cesto Art 119M - 119ME / Basket Art 119M - 119ME / Panier Art 119M - 119ME / Cesto Art 119M - 119ME
- B. N°1 Set guide Sige / Kit Sige slides / Kit coulisses Sige / Kit guías Sige
- C. N°1 Set carter per guide Sige/ Kit carter for Sige Slides / Kit carter pour coulisses Sige / Kit carter para guías Sige
- D. N°2 Distanziali / Spacers / Entretoise / Separadores
- E. N°1 Set spessori fianco mobile 18/20 mm / Cabinet side thickness spacer kit 18/20 mm  
Set d'épaisseur pour cotés des meubles 18/20 mm / Set de espesores para costados del mueble 18/20 mm
- F. N°1 Set spessori fianco mobile 16/19 mm / Cabinet side thickness spacer kit 16/19 mm  
Set d'épaisseur pour cotés des meubles 16/19 mm / Set de espesores para costados del mueble 16/19 mm
- G. N°2 Set tappo / Cap / Bouchon / Tapa
- H. N°1 Sponda / Insert / Insert / Lateral

## UTENSILERIA • TOOLS • OUTILS • INSTRUMENTOS



## MANUTENZIONE/ MAINTENANCE/ ENTRETIEN/ MANTENIMIENTO

Pulire con un panno morbido ed asciutto. Evitare l'uso di solventi e/o abrasivi.  
Clean with a soft, dry cloth. Avoid using solvents or abrasive.  
Nettoyez avec un chiffon sec et doux. N'utilisez pas aucun solvant ou produit abrasif.  
Limpiar con paño suave y seco. Evitar el uso de solventes y/o abrasivos.

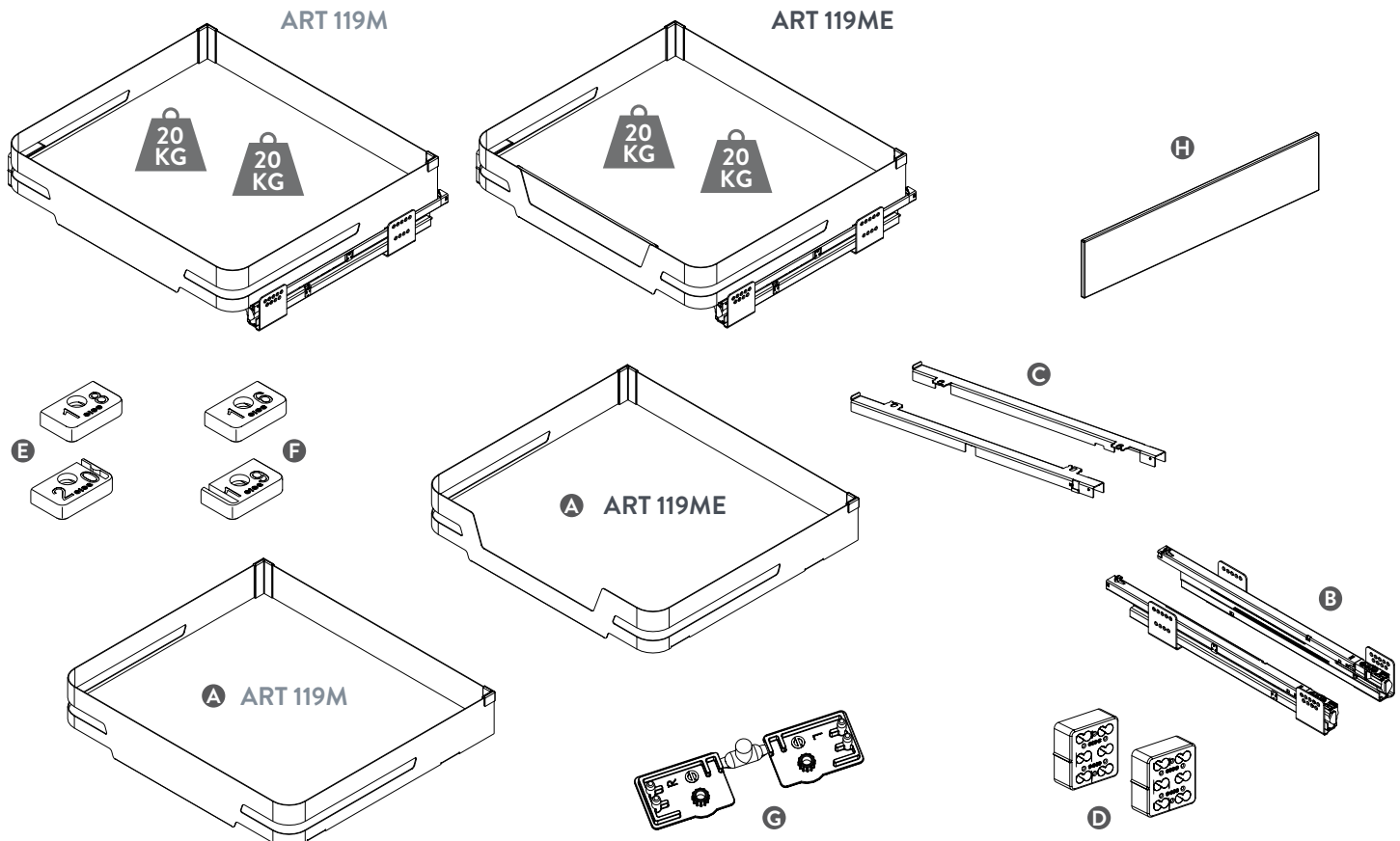
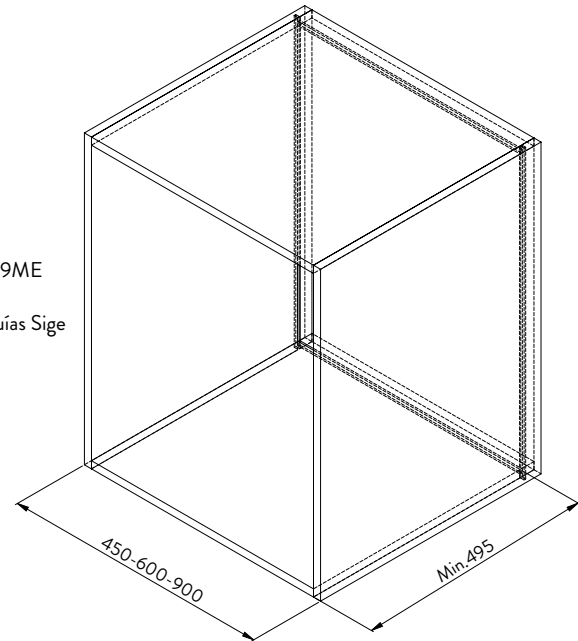

N°12 4x16



Avvitare i distanziali D sul fianco del mobile, lato cerniera rispettando le quote, ed avvitare le guide B sul distanziale D.

NB: per il mobile da 900 mm N. 4 distanziali D.

Screw the spacers "D" on the hinge side of the furniture respecting the quotes and then screw the slides "B" on the spacer "D".

NB: use N. 4 spacers for the furniture of mm. 900

Vissez les entretoises "D" dans la côté du meuble où il y a la charnière et respectez les cotes. Vissez les coulisses "B" dans l'entretoise "D".

NB: utilisez 4 entretoises pour le meuble de 900 mm

Atornillar los separadores "D" en el lado del mueble donde está la bisagra siguiendo las medidas. Atornillar las guías "B" en los separadores "D".

NB: para el mueble de 900 mm utilizar 4 separadores

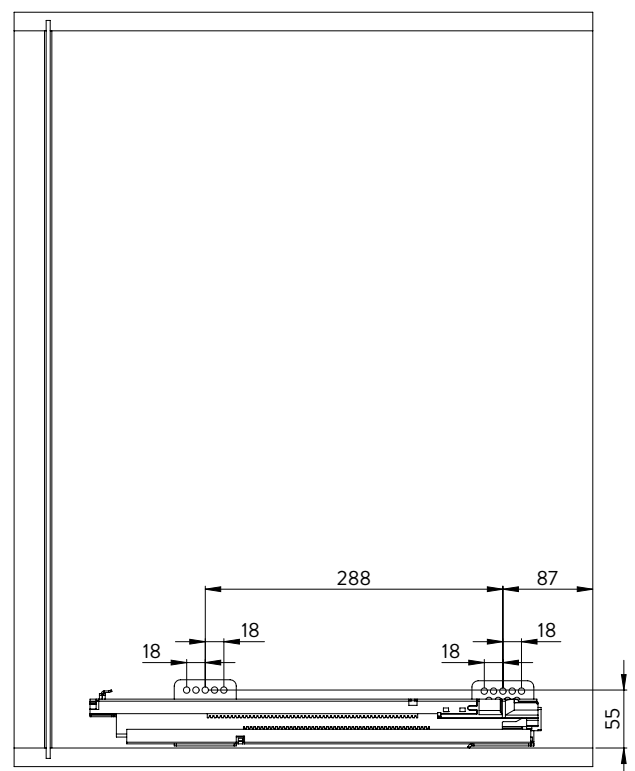
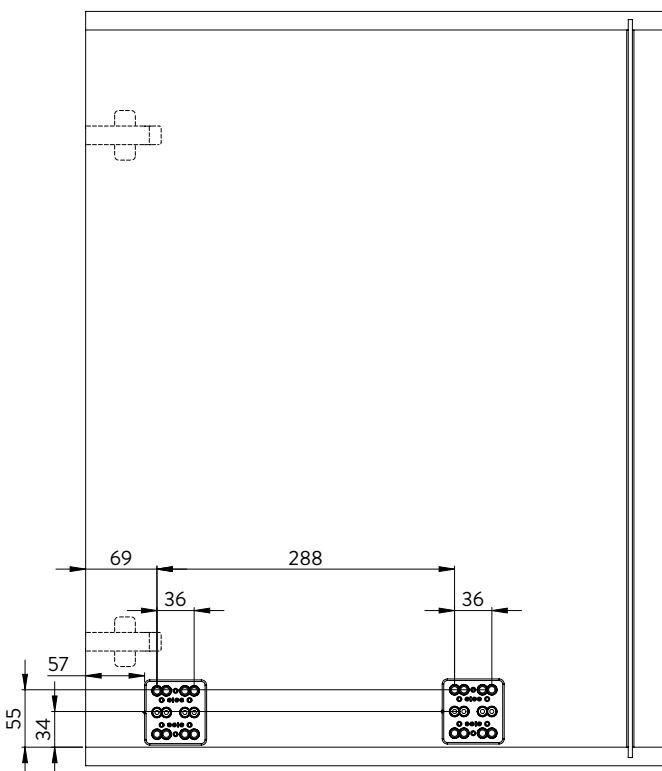
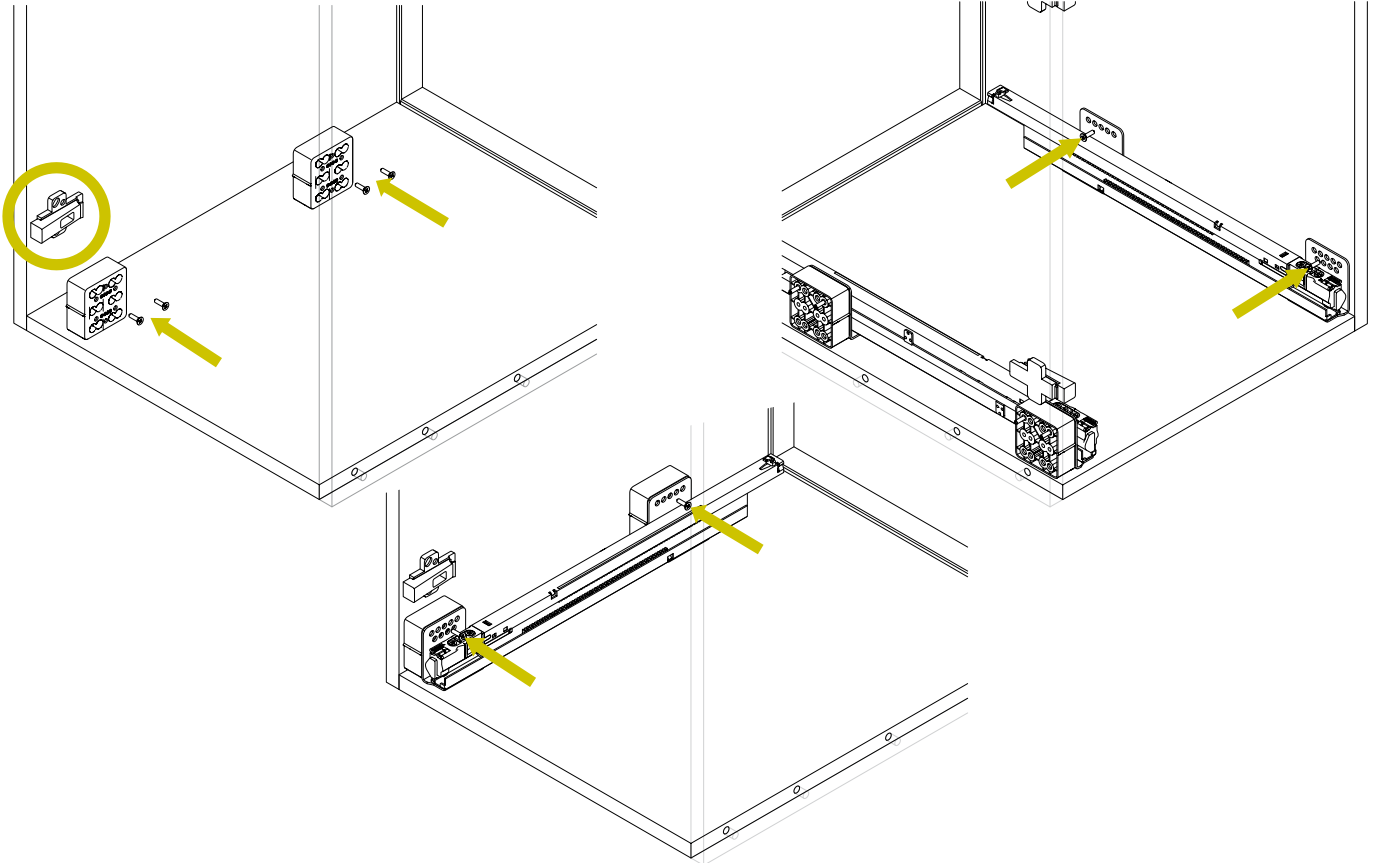

N°4 6,3x14



2

Scegliere i particolari E o F a seconda del fianco mobile. Inserirli nel carter C ed avvitare il tutto tramite l'eurovite sul pianetto.

Choisissez la pièce "E" ou "F" selon la côté du meuble. Mettez-le dans le carter "C" et fixez-le sur le fond avec la euro vis.

Choose the component "E" or "F" depending on the furniture's side. Put the component into the cover "C" and fix it on the bottom by using the euro screw.

Elegir el componente "E" o "F" según el lado del mueble. Insertarlo en el carter "C" y arreglar al fondo con el euro tornillo.

	SPESSORE FIANCO MOBILE CABINET SIDE THICKNESS	COMPONENTE PART
	18 mm	E
	20 mm	
	16 mm	F
	19 mm	

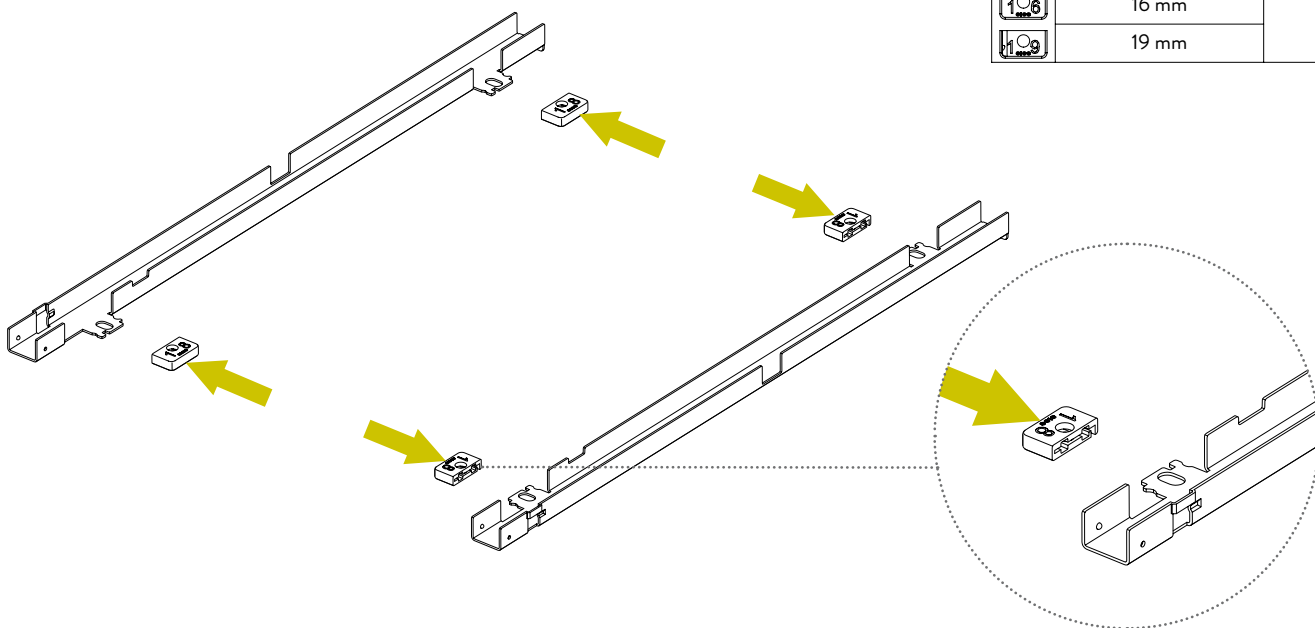

ES SIDE 18 MM

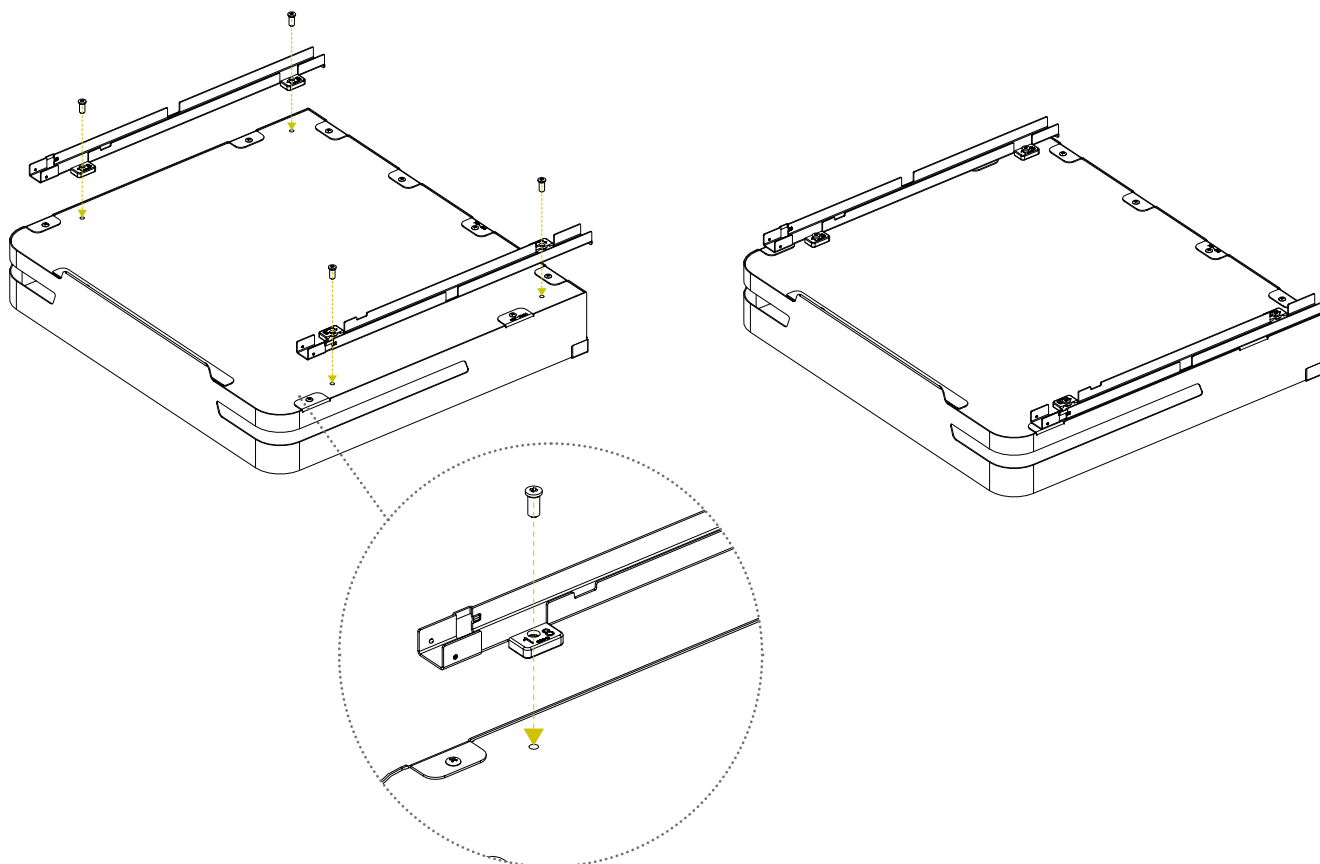

Estrarre le guide B ed agganciare i cesti A nelle guide, inserire il tappo G vedi foto.

Pull out the slides "B" and hang the baskets "A" on the slides; insert the cap "G" as in the picture.

Sortez les coulisses "B" et montez les paniers "A" dans les coulisses. Insérez le bouchon "G" comme dans la photo.

Sacar las guías "B" y colgar los cestos "A" en las guías. Insertar la tapa "G" como en la foto.

